

---

# AQUEOUS PARTS WASHERS

---



Mi-T-M® CORPORATION

## SPECIFICATIONS

Part No./ Model No.	AFL-2M	AFL-2MG	AFL-2MS	AFL-2MGS
Load Height	35"	35"	35"	35"
Turntable Diameter	27"	27"	27"	27"
Work Load (lbs)	1000	1000	1000	1000
Spray Nozzles	15	15	15	15
Water Capacity (gal)	94	94	94	94
Material of Construction	Mild Steel	Mild Steel	304 Stainless	304 Stainless
Heating Source	(3) 4.5 KW	LP/Natural	(3) 4.5 KW	LP/Natural
Power Source	220V 1Ø	220V 1Ø	220V 1Ø	220V 1Ø
Amperage	50	25	50	25
Vent Size (inch)	3.5	3.5	3.5	3.5
Shipping Weight (lbs)	850	850	850	850
Limited Warranty	One Year	One Year	One Year	One Year

*The AFL-2M front load washer provides a fast economical solution for heavy duty cleaning. With a 1000 lbs. work load capacity and 50 PSI and 70 GPM pump output.*



**AFL-2M**

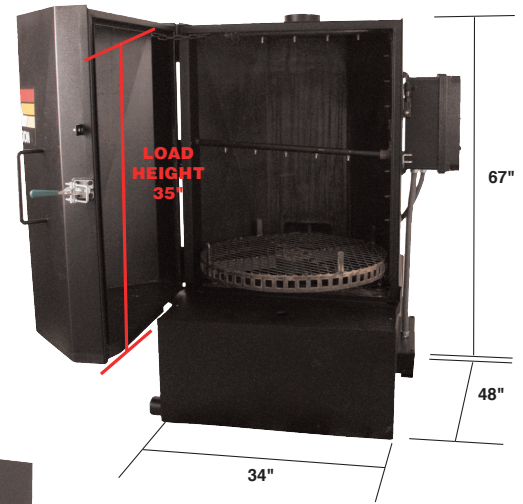

- Mechanical door seal
- Easy to operate controls
- Gear driven turntable
- Heavy duty 12 gauge steel
- 3 H.P. vertical sealless pump
- Stainless steel oil skimmer
- Low water shut-off switch
- Durable powder coated finish
- Available in stainless steel

## SPECIFICATIONS

Part No./ Model No.	AFL-3M	AFL-3MG	AFL-3MS	AFL-3MGS
Load Height	40"	40"	40"	40"
Turntable Diameter (roll out)	36"	36"	36"	36"
Work Load (lbs)	1500	1500	1500	1500
Spray Nozzles	28	28	28	28
Water Capacity (gal)	192	192	192	192
Material of Construction	Mild Steel	Mild Steel	304 Stainless	304 Stainless
Heating Source	(3) 6 KW	LP/Natural	(3) 6 KW	LP/Natural
Power Source	220V 1Ø	220V 1Ø	220V 1Ø	220V 1Ø
Amperage	90	25	90	25
Vent Size (inch)	5.75	5.75	5.75	5.75
Shipping Weight (lbs)	1300	1300	1300	1300
Limited Warranty	One Year	One Year	One Year	One Year

*The AFL-3M front load washer provides a fast economical solution for heavy duty, mid-size parts cleaning. With a 1500 lbs. work load capacity and 50 PSI and 100 GPM pump output.*



**AFL3M**

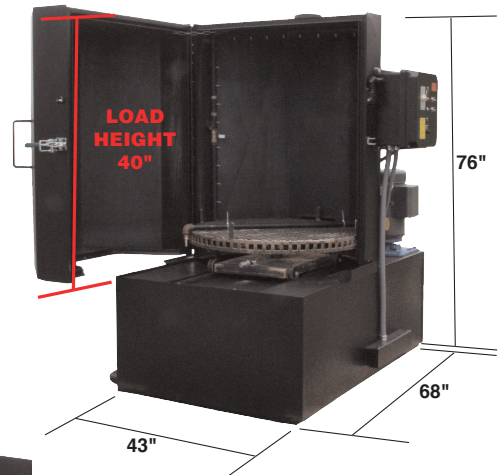

- Mechanical door seal
- Convenient roll-out turntable
- Easy to operate controls
- Gear driven turntable
- Heavy duty 12 gauge steel
- 5 H.P. vertical sealless pump
- Stainless steel oil skimmer
- Low water shut-off switch
- Durable powder coated finish
- Available in stainless steel



# SPECIFICATIONS

Part No./ Model No.	AFL-4M	AFL-4MG	AFL-4MS	AFL-4MGS
<b>Load Height</b>	54"	54"	54"	54"
<b>Turntable Diameter</b> (roll out)	40"	40"	40"	40"
<b>Work Load</b> (lbs)	2000	2000	2000	2000
<b>Spray Nozzles</b>	37	37	37	37
<b>Water Capacity</b> (gal)	243	243	243	243
<b>Material of Construction</b>	Mild Steel	Mild Steel	304 Stainless	304 Stainless
<b>Heating Source</b>	(3) 6 KW	LP/Natural	(3) 6 KW	LP/Natural
<b>Power Source</b>	220V 3Ø	220V 3Ø	220V 3Ø	220V 3Ø
<b>Amperage</b>	60	20	60	20
<b>Vent Size</b> (inch)	5.75	5.75	5.75	5.75
<b>Shipping Weight</b> (lbs)	2000	2000	2000	2000
<b>Limited Warranty</b>	One Year	One Year	One Year	One Year

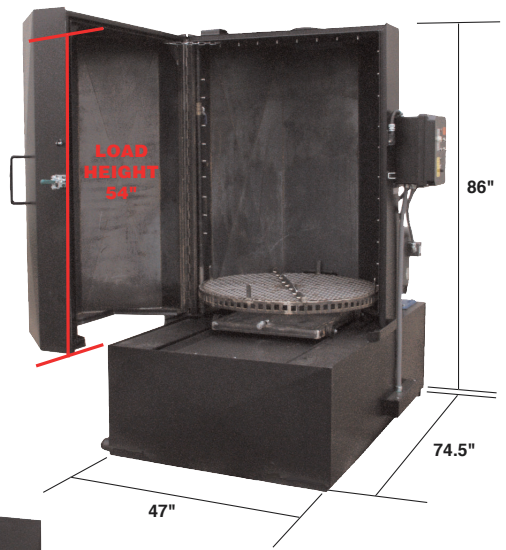

*The AFL-4M front load washer provides a fast economical solution for heavy duty, large parts cleaning. With a 2000 lbs. work load capacity and 50 PSI and 170 GPM pump output.*



- Mechanical door seal
- Convenient roll-out turntable
- Easy to operate controls
- Gear driven turntable
- Heavy duty 12 gauge steel
- 7.5 H.P. vertical sealless pump
- Stainless steel oil skimmer
- Low water shut-off switch
- Durable powder coated finish
- Available in stainless steel

**AFL-4M**

## OPTIONS

Option No.	Description
IMSB-1	Intermediate spray bar
PTO-01	Parts tree
FR-1	Optional filter ready plumbing
F-1	Filter system (AFL units only)
F-2	Filter system (ATL units only)
TC-24H	24 Hour heater timer
TC-24S	24 Hour skimmer timer
AWF	Automatic water fill
DB-2	Double basket (AFL-2M)
DB-3	Double basket (AFL-3M)
DB-4	Double basket (AFL-4M)
9985	Panther tongue skimmer (N/A ATL units)
INS-3	Insulation package (Water tank only)
INS-4	Insulation package (Wash area only)
CAST-1	Casters (ATL-2M, AFL-2M & AFL-3M only)
9001	Soap 40 lbs (5 gallon powder) (Aluminum safe with rust inhibitor)
6109	11"x11"x6" Small parts basket with lid
6110	8"x8"x6" Small parts basket with lid
PEV	Inline powered exhaust ventilator (N/A ATL units)
UG220-3ATL	Upgrade to 220V 3Ø (25 amps)
UG440-3ATL	Upgrade to 440V 3Ø, (2) 4.5 KW (22 amps)
UG440-3	Upgrade to 440V 3Ø (AFL-2M Electric 35 amps/Gas 15 amps) (AFL-3M Electric 45 amps/Gas 15 amps) (AFL-4M Electric 45 amps/Gas 15 amps)
UG220-3	Upgrade to 220V 3Ø (AFL-2M Electric 40 amps/Gas 20 amps) (AFL-3M Electric 60 amps/Gas 20 amps)

1. Front load capability
2. Over-sized hinges allow for easy opening and closing.
3. Large cabinet capacity maximizes cleaning with a large capacity.
4. A mechanical door seal eliminates leakage. No rubber seal to wear out.
5. Easy to use and conveniently located control panel.
6. Heavy duty large gear driven turntable allows for proper parts cleaning.
7. Large capacity solution tank allows for all necessary solution to be contained internally.

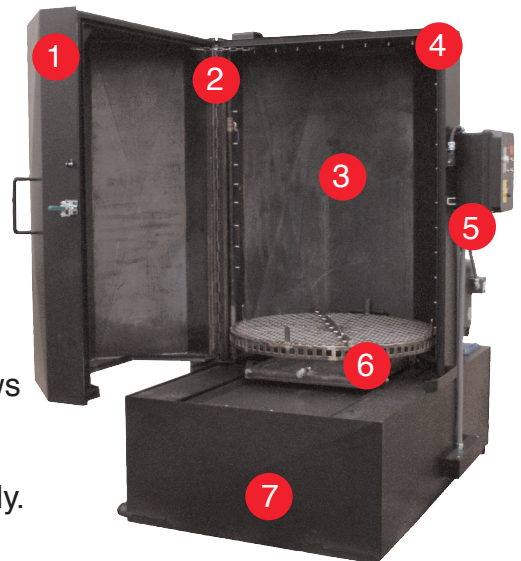

## SPECIFICATIONS

Part No./ Model No.	ATL-2M	ATL-2MS
Load Height	31"	31"
Turntable Diameter	25"	25"
Work Load (lbs)	500	500
Spray Nozzles	17	17
Water Capacity (gal)	35	35
Material of Construction	Mild Steel	304 Stainless
Heating Source	4.5 KW	4.5 KW
Power Source	220V 1Ø	220V 1Ø
Amperage	30	30
Shipping Weight (lbs)	400	400
Limited Warranty	One Year	One Year

*The top loading washer provides an environmentally friendly economical method of cleaning small parts while remaining affordable. With a 500 lbs. work load capacity and 50 PSI and 50 GPM pump output. These units are ideal for automotive shops and batch cleaning of machined pieces and parts.*

**LOAD  
HEIGHT  
31"**

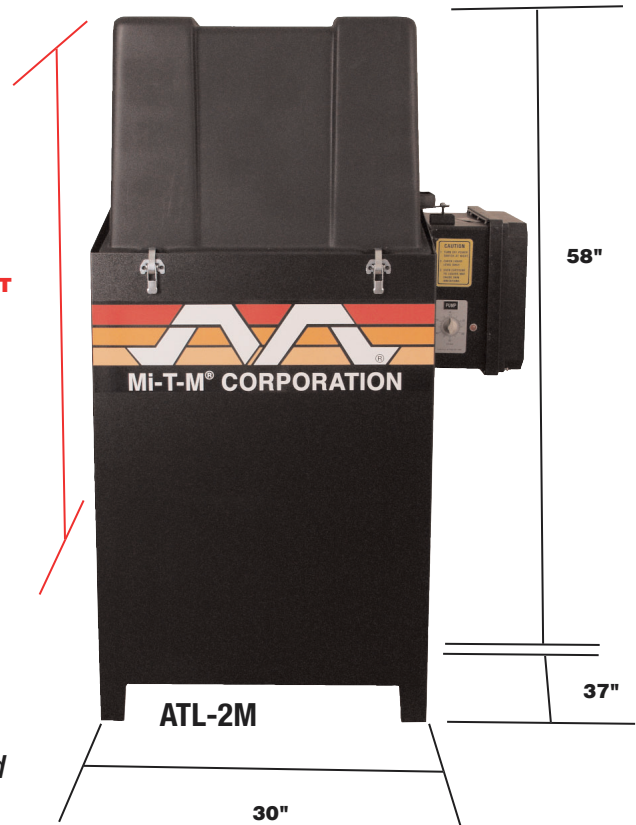

1. Unique steel channel door seal interlocks with the lid and eliminates leakage.
2. Light weight high-strength FRP lid is made of fire retardant and impact resistant material and can stand up to the toughest job.
3. Easy to use and conveniently located control panel.
4. Safety switch automatically shuts unit down when lid is opened.
5. Gear driven turntable allows for proper parts cleaning.
6. Powder coated 12 gauge steel construction ensures long life.
  - 3 H.P. vertical pump
  - Low water shut-off switch
  - Stainless steel oil skimmer



**Shown With Optional IMSB-1**



**Mi-T-M® CORPORATION**

**PRESSURE WASHERS  
AIR COMPRESSORS  
WATER TREATMENT SYSTEMS  
INDUSTRIAL WET/DRY VACUUMS  
AQUEOUS PARTS WASHERS  
JOB SITE TOOL BOXES**

8650 Enterprise Drive · Peosta, IA 52068

**(800) 553-9053** · FAX (563) 556-1235

E-mail: corp@mitm.com

Website: <http://www.mitm.com>

In a continued commitment to improve quality, Mi-T-M reserves the right to make component or design changes when necessary.



©Copyright 2004, Mi-T-M® Corporation

01/01/04

Distributed by: