

Mi-T-M[®] CORPORATION

8650 Enterprise Drive, Peosta IA 52068

319-556-7484 / Fax 319-556-1235

PARTS LIST FOR HSE-1002-0M11 (AFTER SERIAL #22664)

PUMP OIL GRADE:

CAPACITY:

FUEL NOZZLE:

BTU INPUT:

PRESSURE NOZZLE SIZE:

Mi-T-M #AW-4085-0016

11.2 oz

1.10 60°B Delavan

186,000 / hour

4.0

This Parts Listing has been compiled for your benefit. You can be assured your Mi-T-M® hot water pressure washer was constructed and designed with quality and performance in mind using over 25 years experience in the pressure washer business. Each component has been rigorously tested to insure the highest level of acceptance. The contents of this Parts Listing are based on the latest product information available at the time of publication. Mi-T-M® reserves the right to make changes in price, color, materials, equipment, specifications or models at any time without notice.

WARNING

THIS IS A PROFESSIONAL HIGH PRESSURE, HOT WATER PRESSURE WASHER. CAUTION SHOULD BE OBSERVED WHEN USING OR REPAIRING THIS UNIT! READ AND FOLLOW THE SAFETY WARNINGS LISTED BELOW BEFORE ATTEMPTING ANY REPAIRS ON THIS PRESSURE WASHER!

SAFETY WARNINGS

1. NEVER alter or modify the equipment. Be sure any accessory items and system components being used will withstand the pressure developed. Use only genuine Mi-T-M® parts for repair of your pressure washer. Failure to do so can cause hazardous operating conditions and will VOID warranty.
2. NEVER make adjustments on machinery while the unit is connected to the power source. Turning over the machinery by hand during adjustment or cleaning might start the machinery, causing serious injury to the operator.
3. Know how to stop and bleed pressures quickly. Be thoroughly familiar with controls.
4. Before servicing the unit, turn unit off, relieve the water pressure and allow the unit to cool down. Do not make repairs while the unit is running. Service in a clean, dry, flat area. Block the wheels to prevent the unit from moving. Be especially careful to properly dispose of any flammable materials.
5. After testing the machine, DO NOT leave the pressurized unit unattended. Shut off the unit and release trapped pressure before leaving.

Table of Contents

SPECIFICATIONS	3
FLOW CHART	4
GENERAL THEORY OF OPERATION	5
FRAME ASSEMBLY	6
MOTOR/PUMP ASSEMBLY	8
MOTOR (850-0213)	10
HIGH PRESSURE PUMP (3-0071)	12
PUMP SERVICE GUIDE	14
UNLOADER (8-0493) & DETERGENT INJECTOR (46-0752) ASSEMBLY	16
PRESSURE SETTING & TROUBLESHOOTING THE UNLOADER	18
PRESSURE SWITCH (22-0171)	20
COIL DRAIN PLUG (850-0218)	22
HEAT EXCHANGER/BLOWER MOTOR	24
BOILER ASSEMBLY (850-0212)	26
GUN/WAND (850-0179) & ADJUSTABLE PRESSURE DUAL LANCE (850-0185)	28
FUEL TANK (850-0214)	30
FUEL PUMP (3-0020)	32
FUEL SOLENOID (44-0101)	33
CONTROL PANEL	34
WIRE SCHEMATIC	36
WIRE DIAGRAM	37
NOTES	38

SPECIFICATIONS

HSE-1002-0M11.TBL

MODEL NUMBER	HSE-1002-0M11
Operating Pressure (PSI/Bar):	1000/70 (+/- 5%)
Water Volume (GPM/lpm):	2.0/7.6 (+/- 5%)
Outlet Water Temperature (F/C):	140 F/ 60 C (+/- 10 F) rise above inlet ambient (210 F/ 99 C maximum)
Motor:	TEFC
Horsepower	1.5
Phase	Single
Voltage	120
Amps	13
High Pressure Pump:	Direct Driven, Oil Bath, Triplex Piston
Oil Type	Mi-T-M Pump Oil #AW-4085-0016
Oil Capacity (oz./liters)	11.2/0.33
Plungers	Ceramic
Manifold	Forged Brass
Valves	Stainless Steel
Unloader	Preset
Inlet Water Strainer	Removalbe Bowl for inspection and cleaning of Stainless Steel Screen
Heat Dump Valve	Relieves heated water during unloader bypass stage
Detergent Injector:	Adjustable low pressure downstream from pump
Burner Fuel System:	
Fuel Type	No.1 or No.2 Fuel Oil, Diesel or Kerosene
Fuel Capacity (Gal./liters)	4.0/15.1
Fuel Filter/ Water Separator	Spin on (10 micron) filter/ E-Z water drain
Fuel Pump	Two Line, Single Stage
Fuel Pressure (PSI/ BAR)	145/10
Fuel Nozzle	1.10 60 B Delavan
Fuel Consumption (GPH/ LPH)	1.33/5.0 Cont. Burning
Voltage	120
Amps	2
Heat Exchanger:	Vertical, Top fired, Dual Spiral Coil
BTU Input	186,000
Efficiency	86% with #2 Fuel Oil/Diesel
Smoke Density	0-3 per ASTM D2156
Controls:	
On/ Off Switch	Industrial grade cam switch
Pressure Switch	Shuts off burner fuel supply upon trigger release
High Limit Switch	Shuts off burner fuel supply when outlet water temp. exceeds 210 F/ 99 C
Fuel Solenoid:	120 Volt
Safety Relief:	Relieves excess system pressure
Unit Net Weight (Lbs/Kg)	245/111
Unit Shipping Weight (Lbs/Kg)	368/167
Unit Net Dimension (In/Cm)	34Lx29Wx33H/86Lx74Wx84H
Unit Shipping Dimension (In/Cm)	46.5Lx31.5Wx48.5H/118Lx80Wx123H

FLOW CHART

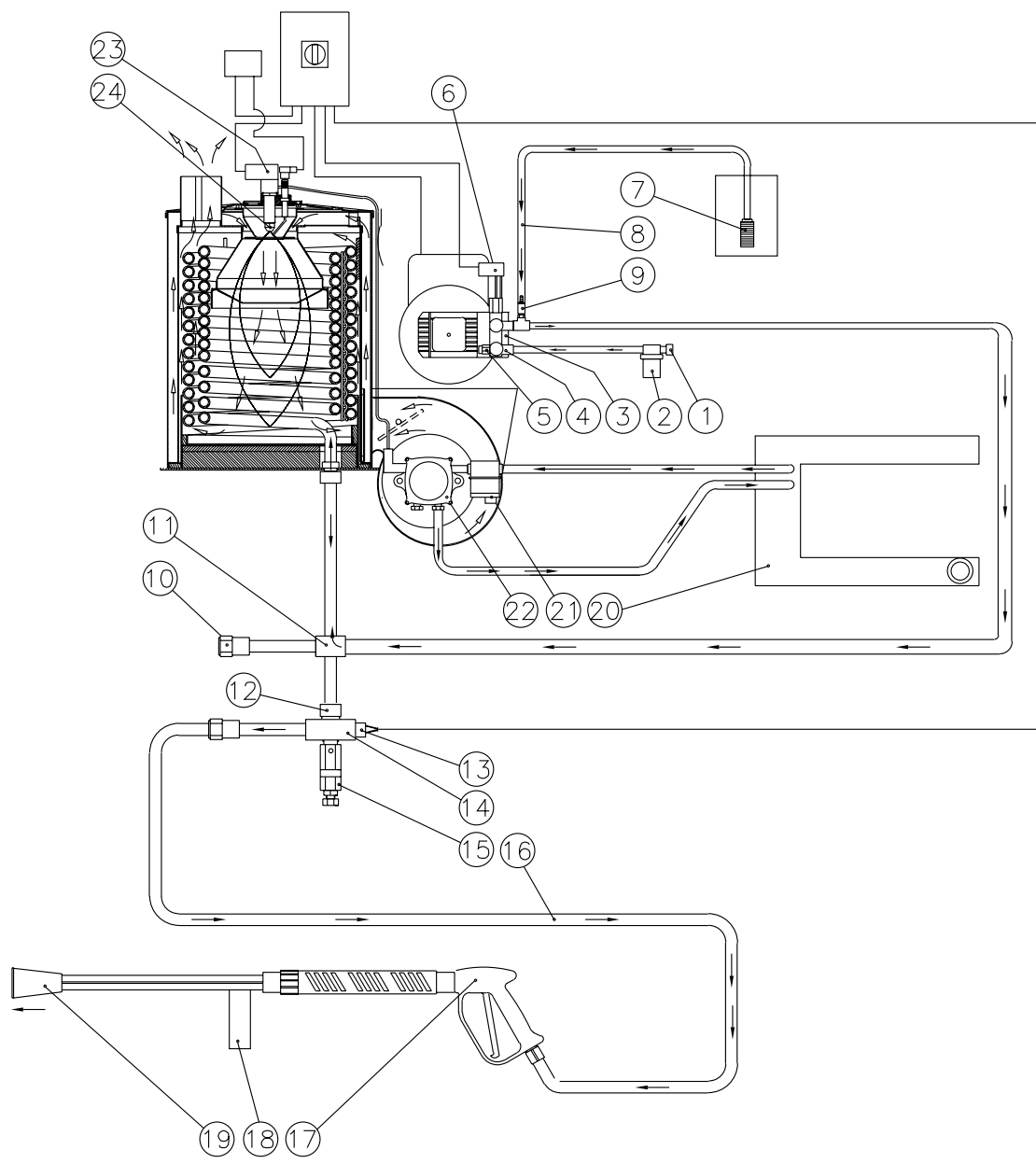

OMHSE002-103098-BAR

GENERAL THEORY OF OPERATION

WATER FLOW: Connect a pressurized water source to the INLET GARDEN HOSE CONNECTION (1) and turn on the water supply. The water will flow through a WATER STRAINER (2) which has a clear inspection bowl.

The water then travels into the TRIPLEX HIGH PRESSURE PUMP (3) which has an UNLOADER (4) that bypasses the water when the trigger gun is closed. To protect the pump from heated water during this bypass stage, a HEAT DUMP VALVE (5) will open at 140°F/ 60°C allowing the heated water to escape. The Heat Dump Valve automatically resets when the water cools. The PRESSURE SWITCH (6) controls the fuel supply to the burner.

When using detergents, the solution passes through the DETERGENT STRAINER (7) located on the DETERGENT HOSE (8). The detergent solution then travels into the ADJUSTABLE LOW PRESSURE DETERGENT INJECTOR (9).

From there, the water may be allowed to flow out of the DRAIN PLUG (10) or through the HEAT EXCHANGER INLET (11) where it is heated when the burner is on. As the water exits the HEAT EXCHANGER OUTLET (12), it enters a safety system which protects the operator from danger. The safety system contains a HIGH TEMPERATURE LIMIT SWITCH (13) which senses the water temperature and shuts off the fuel supply to the burner if it gets too hot. If the unloader fails to by pass the water or the burner remains on when the trigger gun is closed, the SAFETY RELIEF (15) will relieve and allow water to exit safely.

The heated water then flows through the HIGH PRESSURE HOSE (16) and to the TRIGGER GUN ASSEMBLY (17) which allows the operator to control the water spray. When the trigger gun is open, the water flows through the ADJUSTABLE PRESSURE DUAL LANCE (18) and exits the NOZZLE (19).

FUEL FLOW: The Fuel Pump draws fuel from the FUEL TANK (20) through a replaceable FUEL FILTER/WATER SEPARATOR (21) and into the FUEL PUMP (22). Fuel exits the fuel pump, into a FUEL SOLENOID VALVE (23) which controls fuel flow to the FUEL NOZZLE (24) where it ignites and burns in the heat exchanger.

FRAME ASSEMBLY

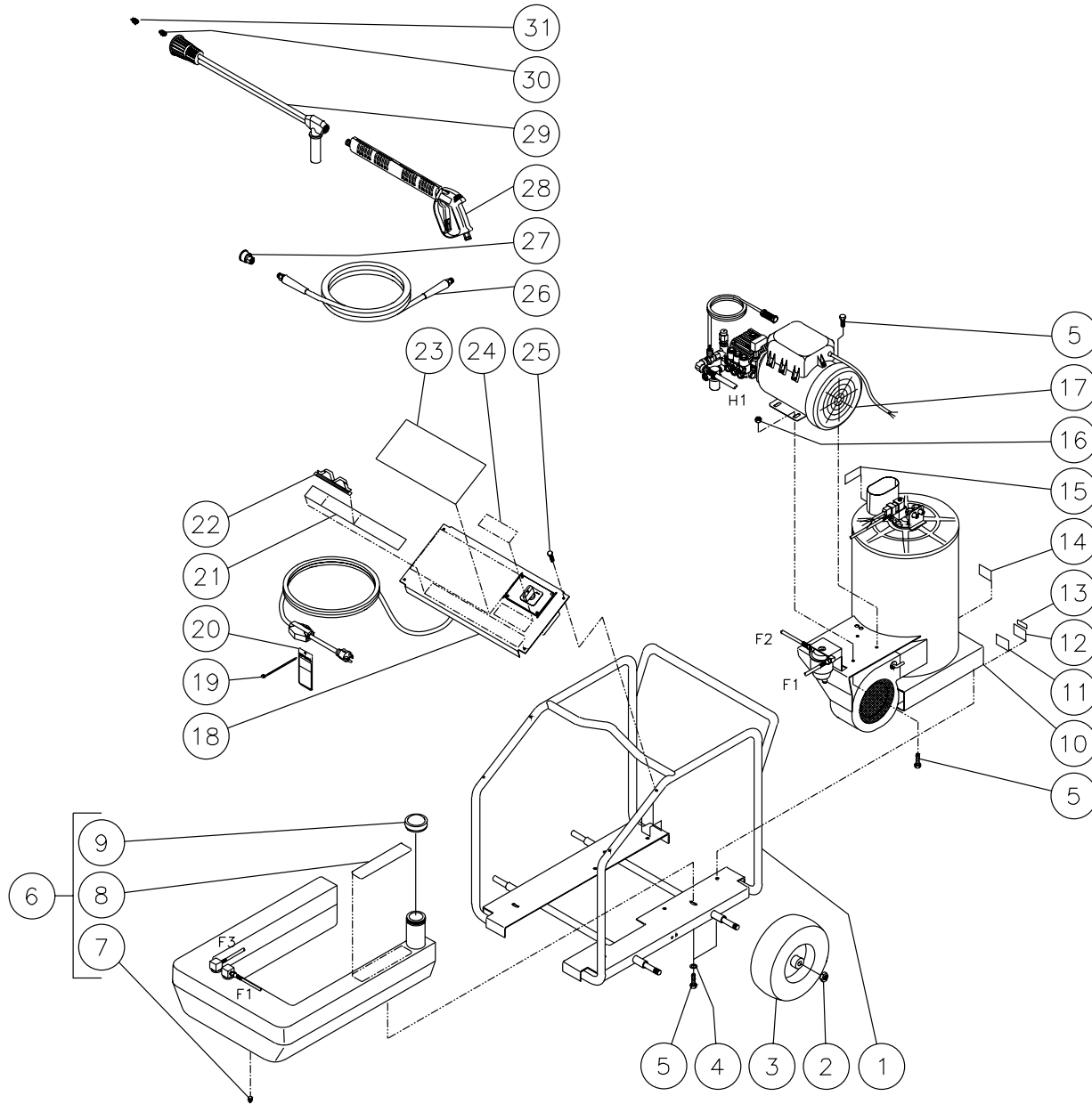

OMHSE005-103098-BAR

FRAME ASSEMBLY

REF. #	DESCRIPTION	PART #	QTY.	REF. #	DESCRIPTION	PART #	QTY.
1	Frame Assembly	5-0128A01	1	17	Motor Pump Assy. (See Exploded Drawing)	N/A Sep.	1
2	Hex Jam Nut	30-0117	4	18	Control Panel (See Exploded Drawing)	N/A Sep.	1
3	Wheel	14-0017	4	19	Cable Tie	33-0022	1
4	Flatwasher	28-0022	8	20	Decal-Hang Tag (E/S)	34-0417	1
5	Bolt	27-9524	12	21	Decal- Stripe	34-0502	1
6	Fuel Tank Assembly	850-0214	1	22	Mi-T-M Logo	62-0087	1
7	Plug	23-0296	1	23	Decal-Warning/Caution./Oper. (E/S)	34-0794	1
8	Decal-Do Not Use Gasoline (E/S)	34-0806	1	24	Decal-Die Cut 1002	34-0302	1
9	Fuel Cap-Vented	12-0033	1	25	Bolt	27-9527	4
10	Heat Exchanger Assy. (See Exploded Drawing)	N/A Sep.	1	26	Hose Assembly	15-0146	1
11	Silver Sticker	N/A	1	27	Screw Connect	17-0035	1
12	Clear Laminate	N/A	1	28	Gun/Lance Assembly	850-0179	1
13	Serial Number	N/A	1	29	Dual Lance Assembly	16-0327	1
14	Decal-Warning: Risk of Explosion (E/S)	34-0807	1	30	Nozzle-1504	18-0054	1
15	Decal-Warning: Hot Surfaces (E/S)	34-0808	1	31	Nozzle- 4060	18-0110	1
16	Hex Nut	30-3023	3				

MOTOR/PUMP ASSEMBLY

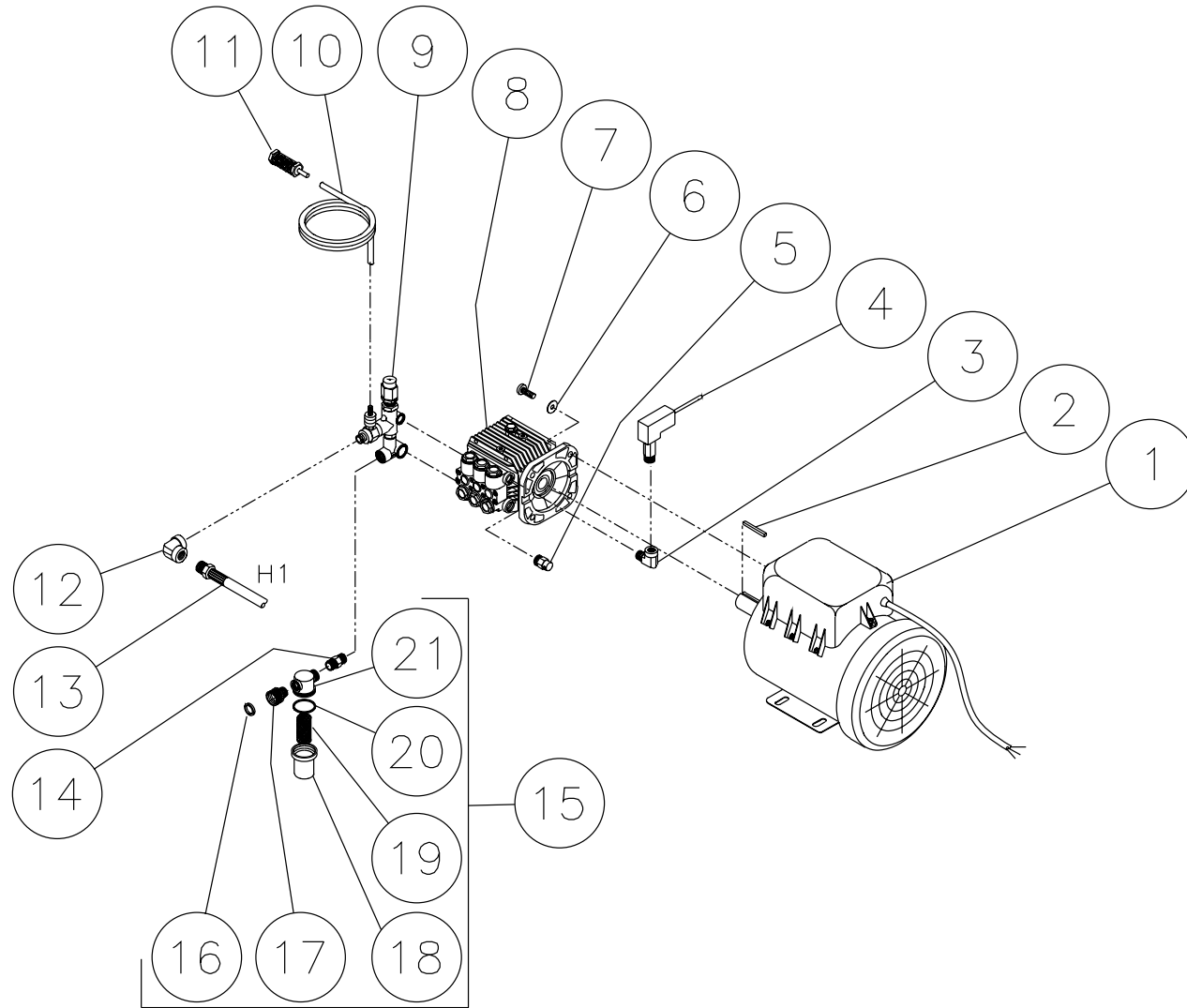

0MHSE007-102998-BAR

MOTOR/PUMP ASSEMBLY

REF. #	DESCRIPTION	PART #	QTY.	REF. #	DESCRIPTION	PART #	QTY.
1	Motor Assembly-1.5 HP	850-0213	1	12	Elbow	23-0307	1
2	Key	43-0072	1	13	Hose Assembly	15-0174	1
3	Elbow	23-0014	1	14	Reducer	23-0018	1
4	Pressure Switch	22-0171	1	15	Strainer Complete (Includes 16-21)	19-0057	1
5	Heat Dump Valve	22-0114	1	16	Garden Hose Gasket	26-0001	1
6	Washer	29-0155	4	17	Garden Hose Swivel	23-0095	1
7	Bolt	27-0118	4	18	Bowl	19-0060	1
8	Pump Assembly	3-0071	1	19	Strainer	19-0059	1
9	Unloader Valve w/ Detergent Injector	8-0493	1	20	Gasket	26-0160	1
10	Detergent Hose *(Six Feet Required)	15-0021	1	21	Cap	19-0058	1
11	Detergent Strainer	19-0050	1	*Must Order in One Foot Lengths.			

MOTOR (850-0213)

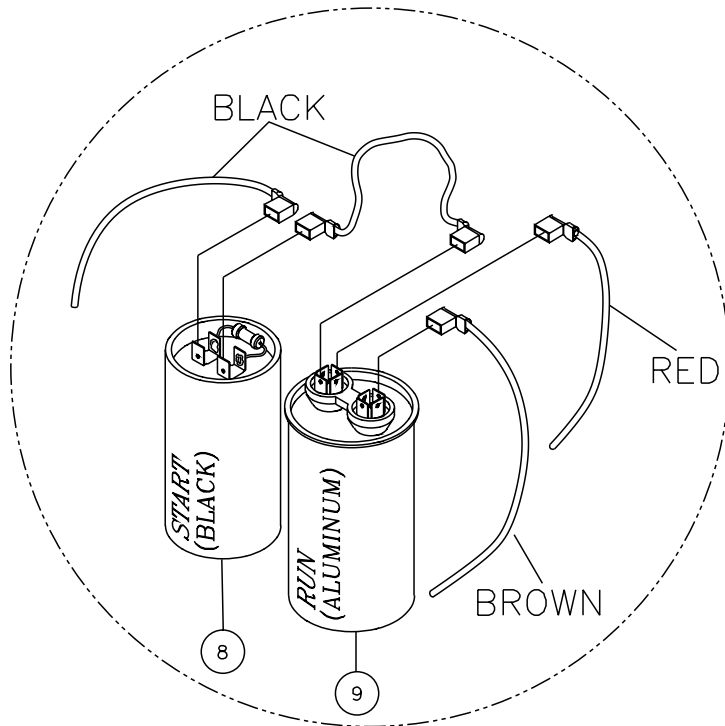

CAPACITOR TERMINAL ASSEMBLY

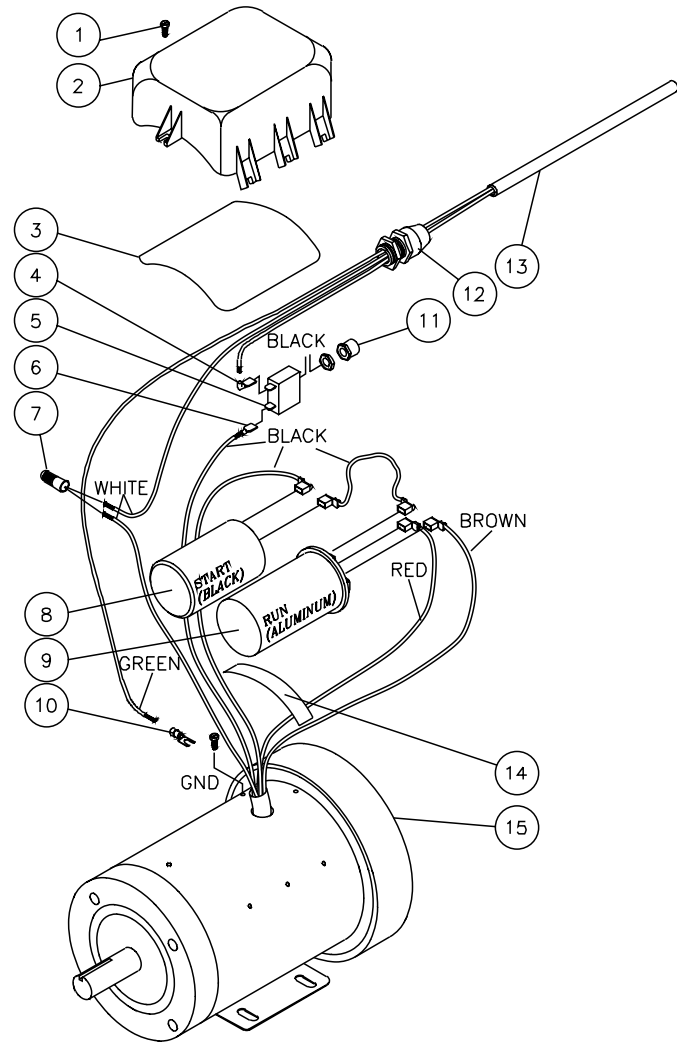

MOTOR (850-0213)			
REF.	DESCRIPTION	PART #	QTY.
1	Screw	27-8389	8
2	Motor Box	52-0041	1
3	O-ring	25-0338	1
4	Terminal	32-0451	2
5	Circuit Breaker 20 Amp	32-0438	1
6	Terminal Spade	32-0221	1
7	Crimp Splice	32-0359	1
8	Capacitor-Start 1.5 w/Motor	32-0411	1
9	Capacitor-Run 1.5 w/Motor	32-0413	1
10	Terminal-Fork	32-0034	1
11	Rubber Boot	32-0441	1
12	Strain Relief	32-0437	1
13	Cord *(Two Feet Required)	32-0440	1
14	Motor Box Strap	52-0042	1
15	Motor	N/A	1
	Motor Assembly Complete-1.5 HP	850-0213	
*Must Order in One Foot Lengths			

HIGH PRESSURE PUMP (3-0071)

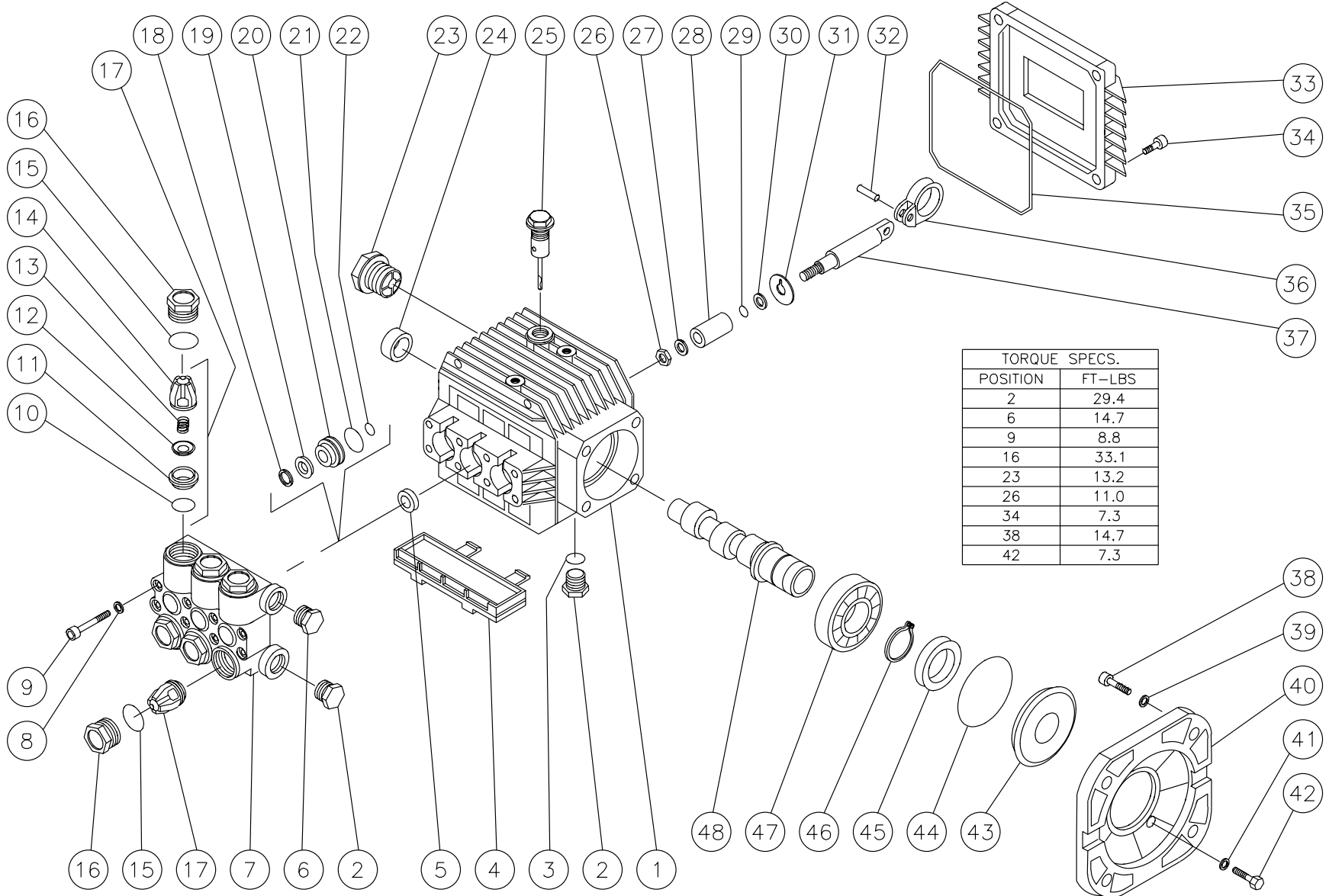

TORQUE SPECS.	
POSITION	FT-LBS
2	29.4
6	14.7
9	8.8
16	33.1
23	13.2
26	11.0
34	7.3
38	14.7
42	7.3

3-0071-100499-RD

HIGH PRESSURE PUMP (3-0071)							
REF. #	DESCRIPTION	PART #	QTY.	REF. #	DESCRIPTION	PART #	QTY.
1	Crankcase	46-0221	1	27	Washer	46-0166	3
2	Plug	39-0018	2	28	Plunger- Ceramic	46-0148	3
3	O-ring	25-0052	1	29	O-ring	25-0045	3
4	Drip Pan	46-0229	1	30	Back-up Ring	25-0143	3
5	Oil Seal	26-0111	3	31	Washer	46-0167	3
6	Plug	39-0017	1	32	Conecting Rod	43-0044	3
7	Manifold- Brass	46-0163	1	33	Crankcase Cover	46-0151	1
8	Lockwasher	29-0153	12	34	Bolt	27-8409	4
9	Bolt	27-8406	8	35	Cover O-ring	25-0332	1
10	O-ring (See 70-0009)	N/A Sep.	6	36	Connecting Rod	46-0152	3
11	Valve Seat (See 70-0009)	N/A Sep.	6	37	Piston Guide	46-0149	3
12	Valve Plate (See 70-0009)	N/A Sep.	6	38	Bolt	27-0118	4
13	Valve Spring (See 70-0009)	N/A Sep.	6	39	Lockwasher	29-0155	4
14	Valve Cage (See 70-0009)	N/A Sep.	6	40	Flange	38-0032	1
15	O-ring	25-0012	6	41	Lockwasher	29-0153	4
16	Valve Plug	39-0035	6	42	Bolt	27-8409	4
17	Valve Assembly (Includes 10-14) (See 70-0009)	N/A Sep.	6	43	Bearing Spacer	46-0087	1
18	Head Ring (See 70-0024)	N/A Sep.	3	44	O-ring	25-0060	1
19	V-packing (See 70-0024)	N/A Sep.	3	45	Oil Seal	26-0126	1
20	V-packing Retainer	46-0158	3	46	Snap Ring	46-0245	1
21	O-ring	25-0141	3	47	Ball Bearing	48-0024	1
22	O-ring	25-0128	3	48	Crankshaft	46-0277	1
23	Oil Level Indicator	46-0114	1		Valve Kit (Includes 3 each 10-14, 17)	70-0009	
24	Bearing	48-0019	1		V-packing Kit (Includes 3 each 18-19, 21-22)	70-0024	
25	Oil Dip Stick	46-0143	1		V-packing Assembly (Includes 18-22)	70-0023	
26	Nut	46-0168	3				

PUMP SERVICE GUIDE

FIG. A

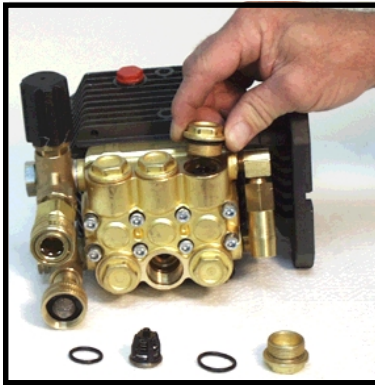
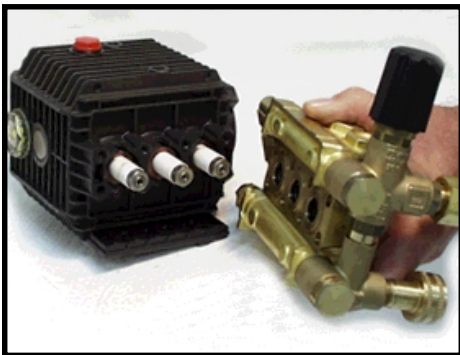

FIG. B



FIG. C



USE THE PARTS LIST ON THE PREVIOUS PAGE TO REORDER PARTS NEEDED TO SERVICE YOUR PUMP.

REPLACING THE VALVE ASSEMBLY:

1. In order to maintain optimum pump performance, replace all the valves at one time. The valve assemblies can be replaced without disrupting plumbing.
2. Remove the valve cap from the manifold (Fig. A).
3. Inspect the o-ring on the valve cap for deterioration. Replace if necessary.
4. Remove the valve assembly from the valve cavity.
5. Remove the o-ring inside the bottom of the valve cavity. Check for signs of severe deterioration of the o-ring. This could reflect excessive wear in the valve cavity of the manifold which is a *normal* occurrence in pumps with an extended life (over 1000 hours). Check the manifold and replace if necessary. (Note: *Normal* wear in the manifold is not covered under warranty.)
6. Install the new o-ring into the bottom of the valve cavity, then place the new valve assembly into the valve cavity.
7. Reinstall the valve cap and torque to 33.1 Ft-lbs (397.2 in-lbs).

REMOVING THE MANIFOLD:

1. Remove the head bolts on the manifold. (Fig. B)

⚠ CAUTION
RISK OF DAMAGE

USE CAUTION NOT TO DAMAGE THE PLUNGERS WHEN REMOVING THE MANIFOLD HEAD FROM THE CRANKCASE .

2. Pull the manifold head from the crankcase (Fig. C). Tap the manifold head lightly with a rubber mallet to loosen if necessary.

NOTE: The V-packing assemblies may come off with the manifold head. If this happens, reinsert the packings in the order given in the "V-Packing Cross Section" illustration shown on the following page.

FIG. D

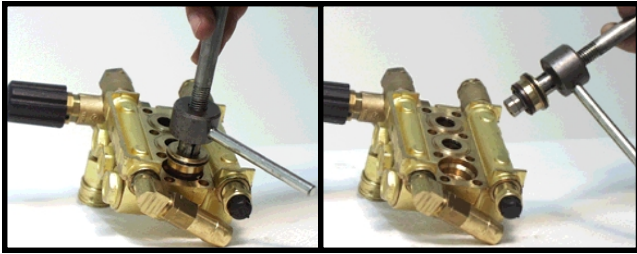

FIG. E



FIG. F



FIG. G

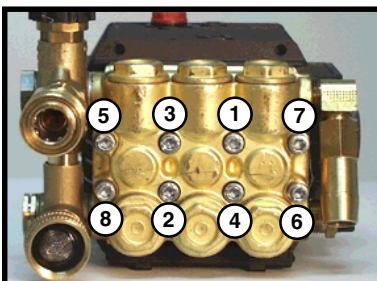

REPLACING V-PACKINGS:

1. In order to maintain optimum pump performance, replace all of the V-Packings and the Low Pressure O-ring Seals at one time. The manifold must be removed from the crankcase before performing this procedure. Use of an extractor is highly recommended for removal of V-Packing Retainer and Packing.
2. Insert the extractor through the center of the V-Packing Retainer and remove the V-Packing Retainer from the manifold (Fig. D).
3. Remove the Low Pressure O-ring Seal from the Packing Retainer with an O-ring Pick.
4. Install the Head Ring, V- Packings, O-rings and Retainer in the order shown in the drawing below.

NOTE: A film of grease on the complete packing assembly will ensure easier installation.

V-PACKING CROSS SECTION



REPLACING PLUNGERS:

1. Remove piston nut and washer from the piston rod.
2. Examine the plungers for cracks and wear. Replace if necessary.
3. Remove the plunger (Fig. F). If the slinger washer comes off with the plunger, replace it before installing the new plunger.
4. Install the replacement parts over the piston guide in the order given:
-Anit-extrusion, O-ring, Plunger and Washer.

NOTE: A film of grease on the o-ring ensures easier installation.

5. Apply thread sealant to the piston guide threads.
6. Install the piston nut and torque to the specifications listed on the pump drawing in your parts list.

REINSTALLING THE MANIFOLD:

1. Apply a coat of grease to each plunger and reinstall the manifold head, taking care not to damage the plungers.
2. Install and tighten the head bolts as shown in the sequence at left (Fig. G). Use your fingers first, then at half the torque specified for your pump. Perform a final torque to 8.8 Ft-lbs (105.6 in-lbs).

UNLOADER (8-0493) & DETERGENT INJECTOR (46-0752) ASSEMBLY

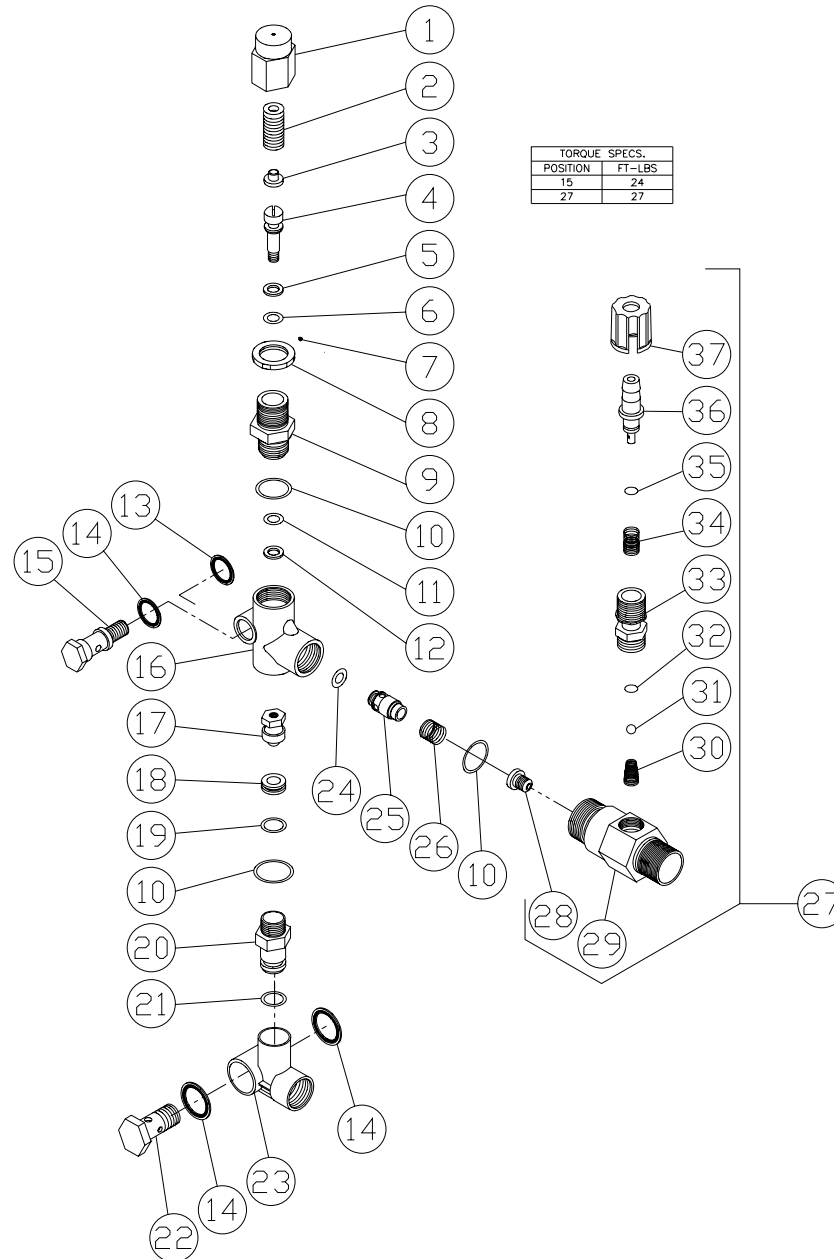

OMGEN278-052998-DCE

UNLOADER (8-0493) & DETERGENT INJECTOR (46-0752) ASSEMBLY							
REF. #	DESCRIPTION	PART #	QTY.	REF. #	DESCRIPTION	PART #	QTY.
1	Adjusting Cap	39-0092	1	21	O-ring	25-0376	1
2	Spring	49-0120	1	22	Connector	23-0285	-
3	Spring Retainer	8-0421	1	23	Bypass Fitting	N/A	1
4	Piston Stem	46-0324	1	24	O-ring	25-0375	1
5	Back-up Ring	25-0206	1	25	Flow Balancer	8-0426	1
6	O-ring (See 70-0168)	N/A Sep.	1	26	Spring	49-0121	1
7	Set Screw	8-0479	1	27	Detergent Injector (Inc. 28-37)	46-0752	1
8	Loknut	46-0651	1	28	Orifice- 1.8mm	50-0146	1
9	Piston Retainer	8-0424	1	29	Injector Body (See 46-0752)	N/A Sep.	1
10	O-ring (See 70-0168)	N/A Sep.	3	30	Spring	N/A Sep.	1
11	O-ring (See 70-0168)	N/A Sep.	1	31	Ball (See 852-0056)	N/A Sep.	1
12	Back-up Ring	25-0203	1	32	O-ring (See 852-0056)	N/A Sep.	1
13	Washer	8-0433	1	33	Piston Retainer (See 852-0056)	N/A Sep.	1
14	Washer	8-0427	3	34	Spring	49-0056	1
15	Connector	23-0286	1	35	O-ring (See 852-0056)	N/A Sep.	1
16	Body	N/A	1	36	Shutter Barb	50-0157	1
17	Valve and Ball Assembly	46-0320	1	37	Adjusting Knob	50-0158	1
18	Bypass Seat	8-0430	1		Unloader Repair Kit (Inc. 4-6, 10-12, 17-19, 21)	70-0168	
19	O-ring	25-0202	1		Repair Kit (Inc. 30-32, 35)	852-0056	
20	Bypass Filter	N/A	1				

PRESSURE SETTING & TROUBLESHOOTING THE UNLOADER

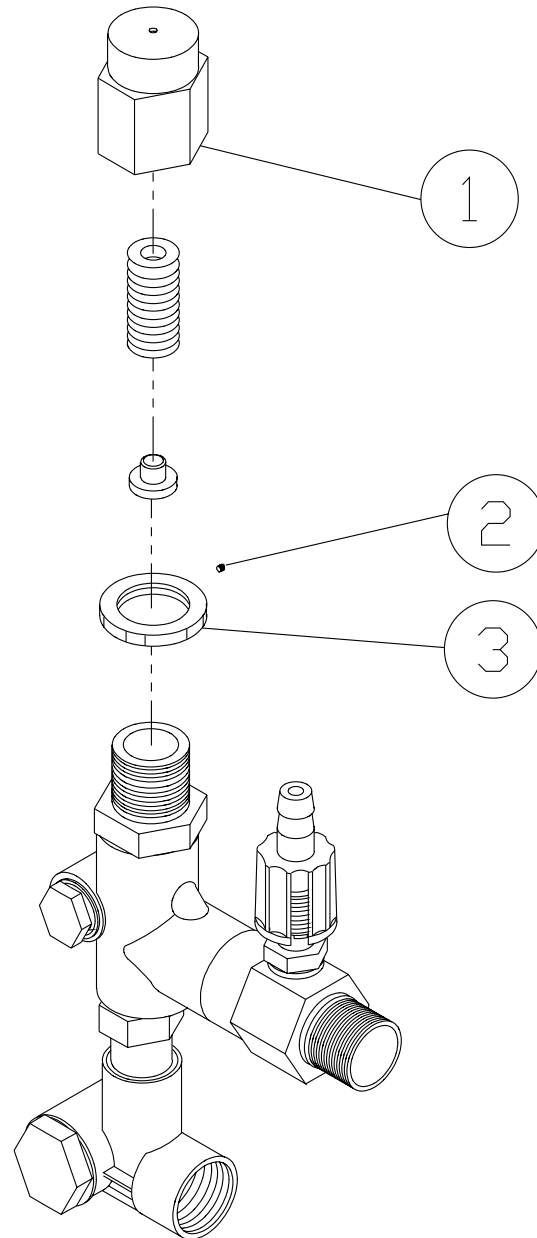

TOOLS NEEDED:

5000 PSI GAUGE
2.5MM ALLEN WRENCH
ADJUSTABLE WRENCH

TO SET MAXIMUM SPRAY PRESSURE AND BYPASS PRESSURE:

Refer to unloader drawing on the previous page. Install test gauge in the discharge line after the unloader valve. With the pump operating but the spray gun off, loosen SET SCREW (2) using 2.5mm Allen wrench and move the ADJUSTABLE LOCKNUT (3) downwards. With proper nozzle installed in spray gun, squeeze trigger and turn ADJUSTING CAP (1) **clockwise** to desired maximum spray pressure. Tighten the ADJUSTABLE LOCKNUT (3) against the ADJUSTING CAP (1). Then tighten SET SCREW (2) securely and release trigger. Squeeze and release trigger several times to verify consistency of spray pressure setting. Spray pressure should fall within 5% of original setting. Bypass pressure (the reading on the gauge when the trigger is released) should exceed the spray pressure by approximately 15-20%. If valve fails to repeat within specifications, repeat the steps above and assure all final settings are tight.

TROUBLESHOOTING:

SYSTEM WILL NOT COME UP TO FULL DESIGNATED PRESSURE:

- * Spray nozzle worn or nozzle orifice is too large in relation to pump flow rate.
- * Adjusted improperly. Refer to pressure adjustment section for proper procedures.
- * Bypass valve (within unloader) is obstructed or leaking. Remove and clean bypass cartridge or replace.
- * Flow rate of pump inadequate. Assure designated flow rate of pump is adequate in relation to spray nozzle size.

PRESSURE SPIKES IN DISCHARGE LINE DURING BYPASS MODE:

- * Pressure adjustment too tight. Refer to pressure adjustment section for proper adjustment procedures.

UNLOADER CYCLES WHILE IN BYPASS MODE:

- * External leak on unloader or in downstream fittings. Inspect all high pressure lines (including gun and hose) for any signs of leakage and repair as necessary.
- * Non-return valve. (within the unloader) damaged, obstructed or worn. Inspect and replace as necessary. Replace with #70-0168.

PRESSURE SWITCH (22-0171)

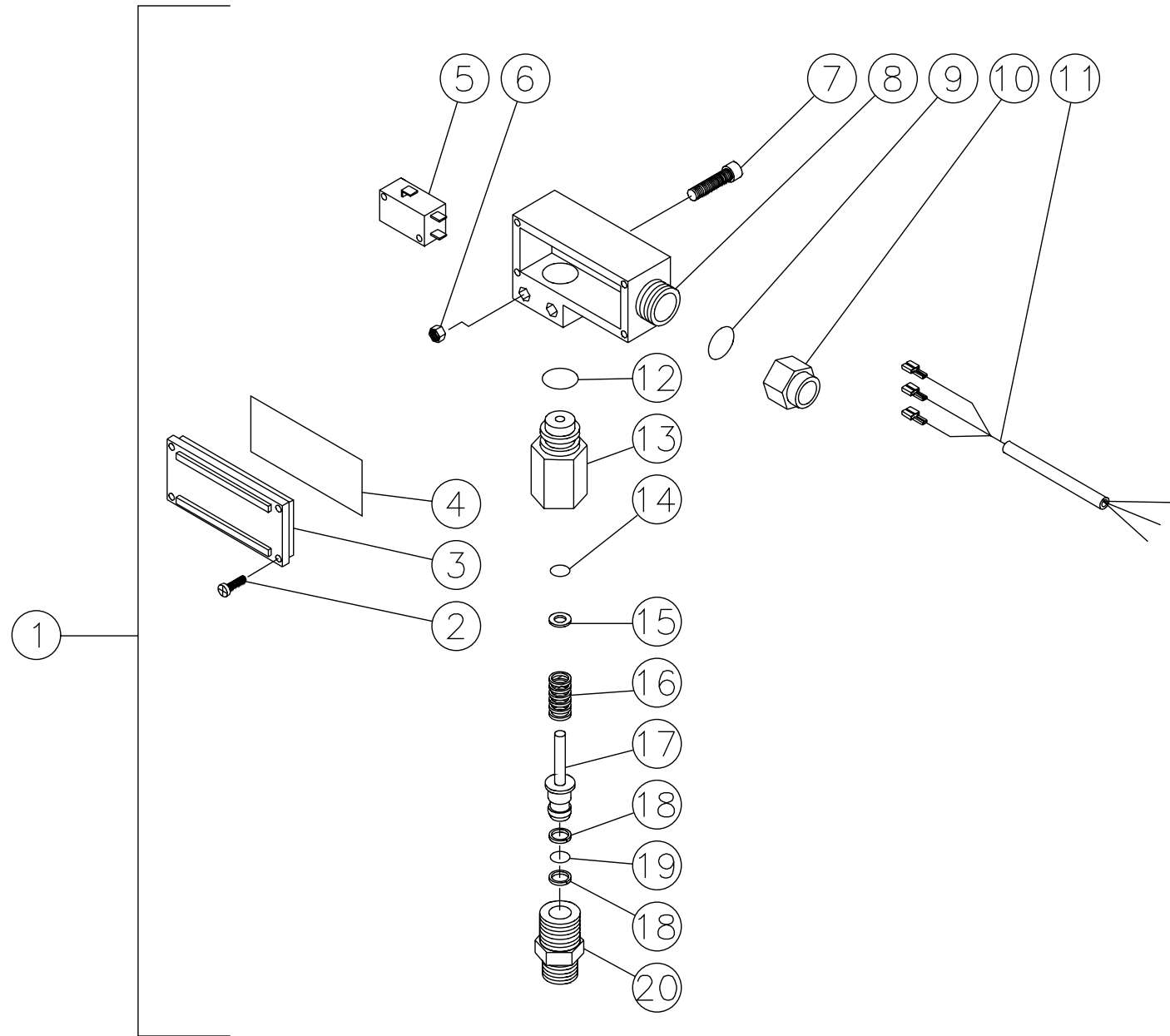

0MGEN253-021299-BAR

0MGEN253-22-0171-021299-BAR

PRESSURE SWITCH (22-0171)			
REF. #	DESCRIPTION	PART #	QTY.
1	Pressure Switch (218 PSI/15 Bar)	22-0171	1
2	Screw	N/A	4
3	Cover	N/A	1
4	O-ring	N/A	1
5	Micro Switch	N/A	1
6	Hex Nut	N/A	2
7	Screw	N/A	2
8	Housing	N/A	1
9	O-ring	N/A	1
10	Bushing Nut (Blue)	N/A	1
11	Wire Assembly	N/A	1
12	O-ring	N/A	1
13	Spring Housing	N/A	1
14	O-ring (See 70-0007)	N/A Sep.	1
15	Spacer	28-0218	1
16	Spring (218 PSI/15 Bar)	49-0107	1
17	Piston	N/A	1
18	Back-up Ring (See 70-0007)	N/A Sep.	2
19	O-ring (See 70-0007)	N/A Sep.	1
20	Hex Nipple	N/A	1
	O-ring Kit (Includes 14, 18, 19)	70-0007	

COIL DRAIN PLUG (850-0218)

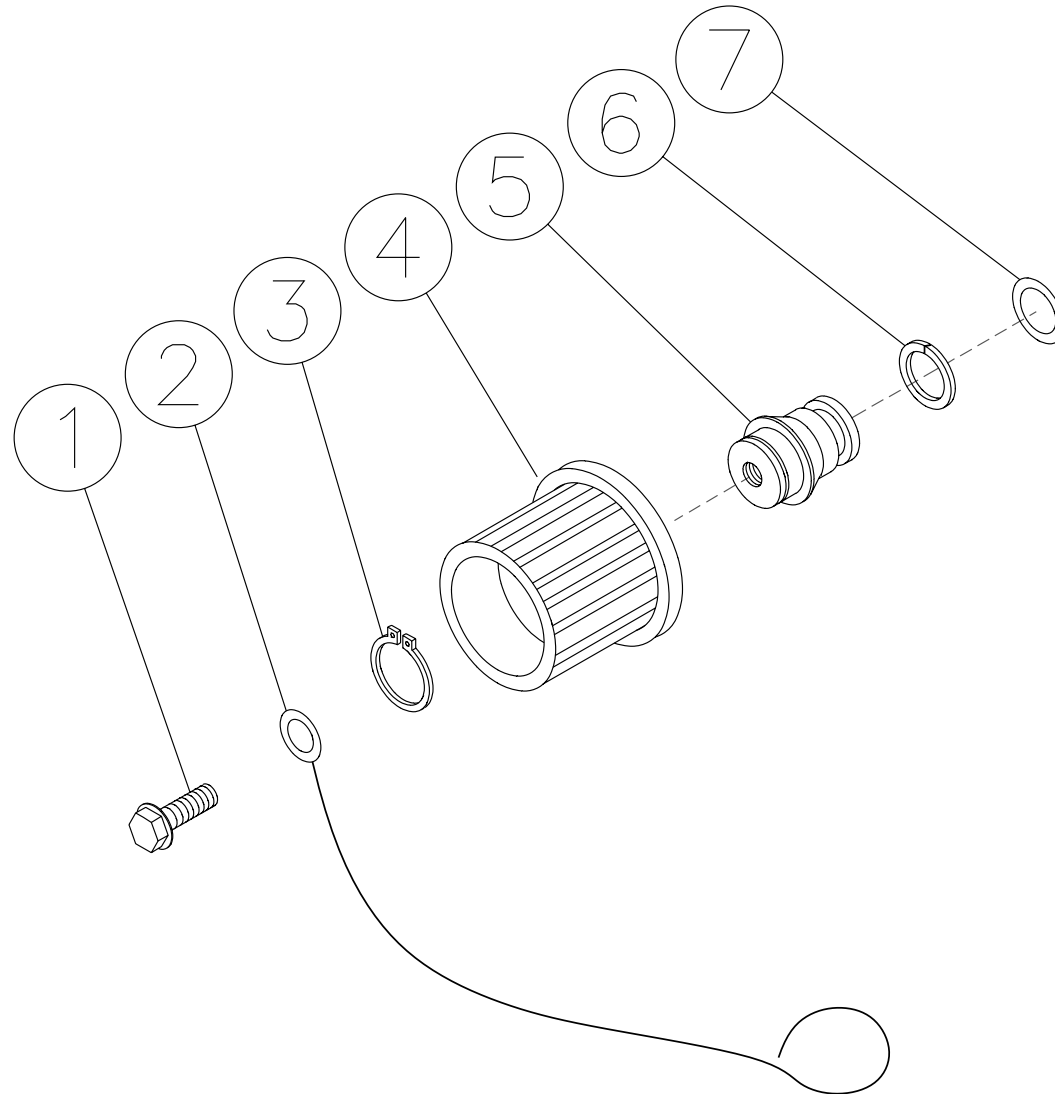

850-0218-041597-BAR

850-0218-041597-BAR

COIL DRAIN PLUG (850-0218)			
REF. #	DESCRIPTION	PART #	QTY.
1	Bolt	27-9526	1
2	Retaining Cable	33-0260	1
3	Snap Ring	33-0261	1
4	Hand Wheel	16-0239	1
5	Plug	24-0147	1
6	Back-up Ring	25-0424	1
7	O-ring	25-0423	1
NOTE: Ref. #1 must be torqued to 16lbs. when being installed!			

HEAT EXCHANGER/BLOWER MOTOR

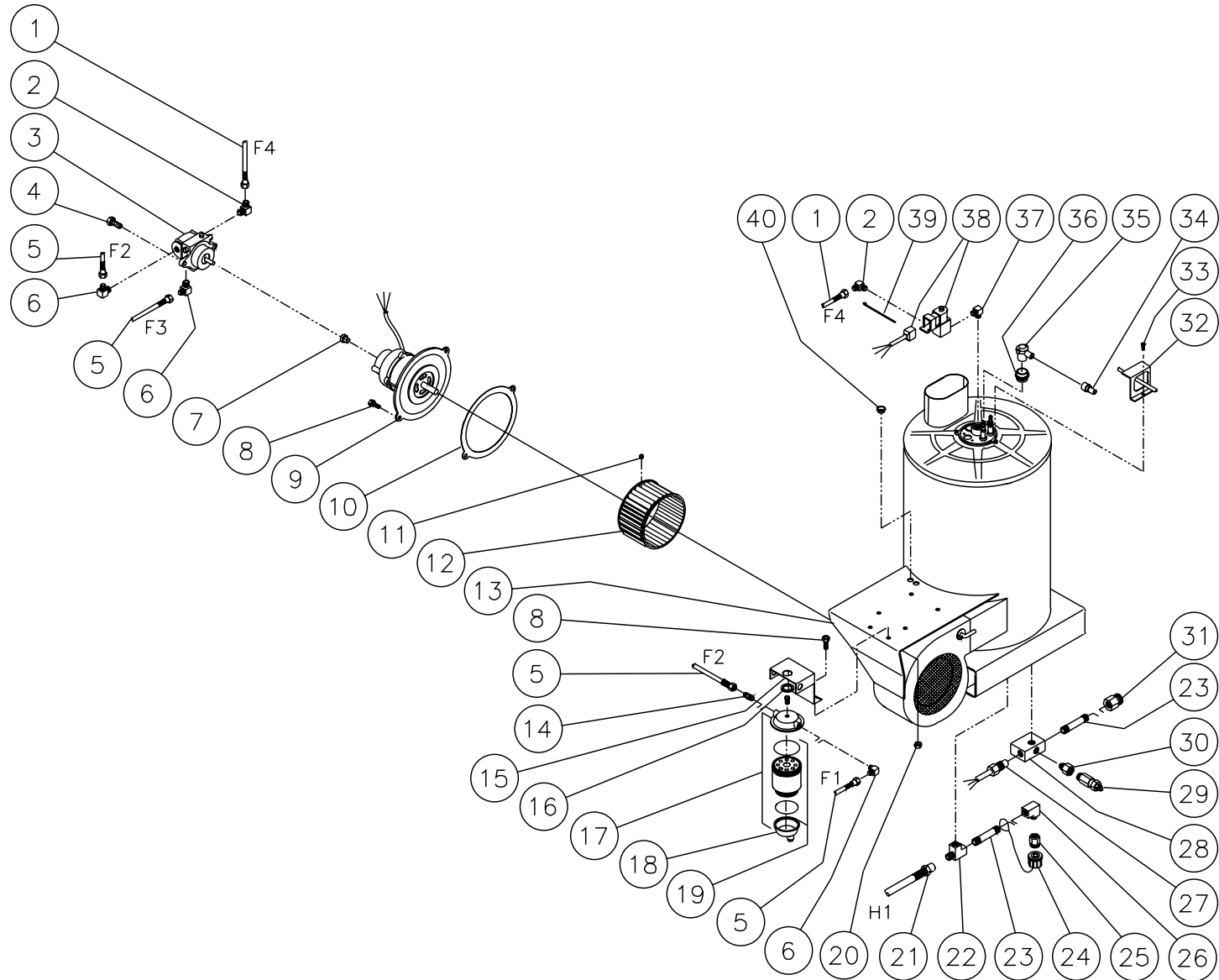

HEAT EXCHANGER/ BLOWER MOTOR								
REF. #	DESCRIPTION	PART #	QTY.		REF. #	DESCRIPTION	PART #	QTY.
1	Fuel Hose Assembly	15-0173	1		22	Tee	23-0058	1
2	Elbow	23-0287	2		23	Pipe Nipple	24-0141	2
3	Fuel Pump	3-0020	1		24	Coil Drain Plug Assembly	850-0218	1
4	Bolt	27-8898	2		25	Adapter	23-0279	1
5	Fuel Hose Assembly	15-0147	3		26	Elbow	23-0306	1
6	Elbow	23-0237	3		27	High Limit Temp. Switch 120V	32-0423	1
7	Fuel Pump Flex Coupler	33-0265	1		-	High Limit Temp. Switch 240V	32-0421	1
8	Bolt	27-9524	4		28	Coil Outlet Block	24-0138	1
9	Blower Motor-120 Volt	2-0085	1		29	Pressure Relief Valve	22-0272	1
-	Blower Motor-240 Volt	2-0086	1		30	Adapter	23-0369	1
10	Shim	20-0460A01	1		31	Adapter	23-0197	1
11	Set Screw	30-3031	1		32	Electrode Bracket	20-0417A01	1
12	Blower Fan	44-0103	1		33	Screw	27-8803	3
13	Boiler Assembly	850-0212	1		34	Insulator- Black	32-0375	2
14	Male Connector	23-0247	1		35	Electrode Connector Cap	44-0083	2
15	Bracket for Fuel Water Seperator	20-0416A01	1		36	Electrode Boot	32-0418	2
16	Gasket	26-0001	1		37	Elbow	23-0249	1
17	Fuel Water Seperator	19-0070	1		38	Fuel Solenoid- 120V	44-0101	1
18	Fuel Water Sep. Bowl	19-0071	1		-	Fuel Solenoid- 240V	44-0102	1
19	Fuel Water Sep. Strainer	19-0053	1		39	Cable Tie	33-0022	1
20	Hex Nut	30-3023	2		40	Bushing	9-0028	2
21	Hose Assembly	15-0174	1					

BOILER ASSEMBLY (850-0212)

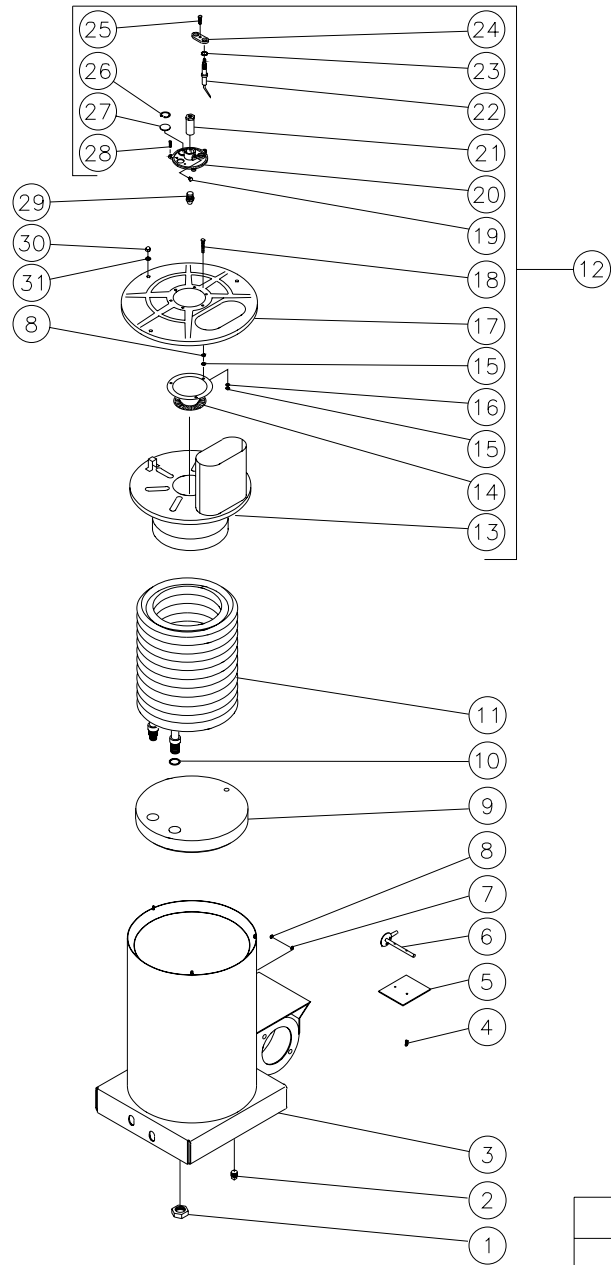

850-0212-1113099-BAR

BOILER ASSEMBLY (850-0212)								
REF. #	DESCRIPTION	PART #	QTY.		REF. #	DESCRIPTION	PART #	QTY.
1	Hex Nut	30-0121	2		17	Top Pan	20-0323	1
2	Plug	24-0034	1		18	Bolt	27-8806	3
3	Heat Exchanger Outer Wrap-Black	20-0404A01	1		19	Bolt	27-8805	1
4	Bolt Hex Head	27-8879	2		20	Support Plate	33-0183	1
5	Air Diverter Plate-Black	20-0378A01	1		21	Nozzle Holder	33-0182	1
6	Air Diverter Stem Assembly-Black	20-0377A01	1		22	Electrode	32-0377	2
7	Lockwasher	28-1009	1		23	Washer	28-1007	2
8	Nut	30-6001	4		24	Electrode Mounting Plate	33-0180	1
9	Bottom Insulation	33-0267	1		25	Bolt	27-8807	1
10	Washer	28-0521	2		26	Snap Ring	25-0290	1
11	Heat Exchanger Coil Assembly	66-0009	1		27	Sight Glass	33-0179	1
12	Pan Assembly (Includes 13-28)	70-0184	1		28	Bolt	27-8803	3
13	Exhaust Pan	20-0324	1		29	Fuel Nozzle	18-0268	1
14	Heat Deflector	20-0325	1		30	Acorn Nut	30-6002	3
15	Nut	30-6001	6		31	Star Washer	28-1028	3
16	Lockwasher	28-1009	3			Boiler Assembly (Inc. 1-28, 30, 31)	850-0212	

GUN/WAND (850-0179) & ADJUSTABLE PRESSURE DUAL LANCE (850-0185)

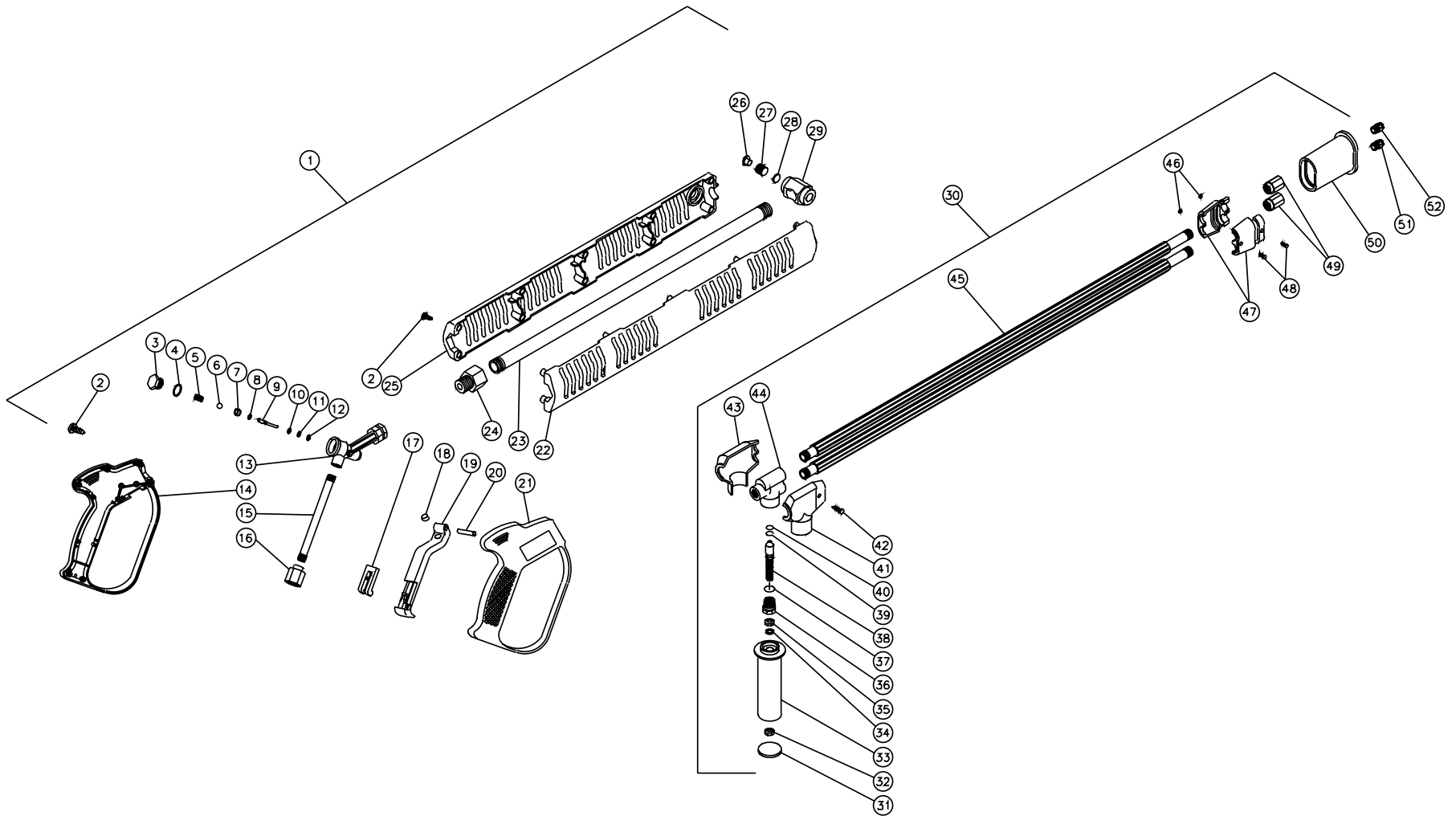

OMGEN256-022399-BAR

GUN/WAND (850-0179) & ADJUSTABLE PRESSURE DUAL LANCE (850- 0185)							
REF. #	DESCRIPTION	PART #	QTY.	REF. #	DESCRIPTION	PART #	QTY.
1	Gun w/Lance Assembly (2-29)	850-0179	1	28	Spacer	16-0282	1
2	Screw	27-8382	13	29	Lance Holder (See 850-0179)	N/A Sep.	1
3	Plug (See 70-0057)	N/A Sep.	1	30	Adjustable Dual Lance Assembly (Includes 31-51)	850-0185	1
4	O-ring (See 70-0057)	N/A Sep.	1	31	Handle Plug	16-0312	1
5	Spring (See 70-0057)	N/A Sep.	1	32	Hex Nut	30-3002	1
6	Ball (See 70-0057)	N/A Sep.	1	33	Handle	16-0313	1
7	Seat (See 70-0057)	N/A Sep.	1	34	Washer	28-1021	1
8	O-ring (See 70-0057)	N/A Sep.	1	35	Hex Nut	30-3010	1
9	Pin (See 70-0057)	N/A Sep.	1	36	Hex Adapter	23-0271	1
10	Washer (See 70-0057)	N/A Sep.	1	37	O-ring	25-0351	1
11	O-ring (See 70-0057)	N/A Sep.	1	38	Piston Stem	16-0314	1
12	Back-up Ring (See 70-0057)	N/A Sep.	1	39	Back-up Ring	25-0352	1
13	Housing	23-0295	1	40	O-ring	25-0353	1
14	Plastic Housing (Left Side)	16-0336	1	41	Upper Protector	16-0315	1
15	Pipe	21-0095	1	42	Lower Protector	16-0316	1
16	Nipple	23-0174	1	43	Body	23-0272	1
17	Trigger Safety Lock	16-0332	1	44	Screw	27-8862	1
18	Trigger Rest	16-0333	1	45	Lance w/Protective Cover	16-0328	2
19	Trigger	16-0335	1	46	Hex Nut	30-3060	2
20	Trigger Pin	43-0069	1	47	Pipe Clamp	16-0318	2
21	Plastic Housing (Right Side)	16-0334	1	48	Screw	27-8861	2
22	Guard Lance (Right Side)	16-0279	1	49	Nipple	24-0127	2
23	Pipe	16-0277	1	50	Nozzle Protector	16-0319	1
24	Adapter	16-0283	1	51	Nozzle-4060	18-0110	1
25	Guard Lance (Left Side)	16-0278	1	52	Nozzle-1503	18-0053	1
26	Plug	39-0076	1		Gun Repair Kit (Includes 3-12)	70-0057	
27	Screw	49-0103	1		O-ring Kit (Includes 37, 39, 40)	70-0143	

FUEL TANK (850-0214)

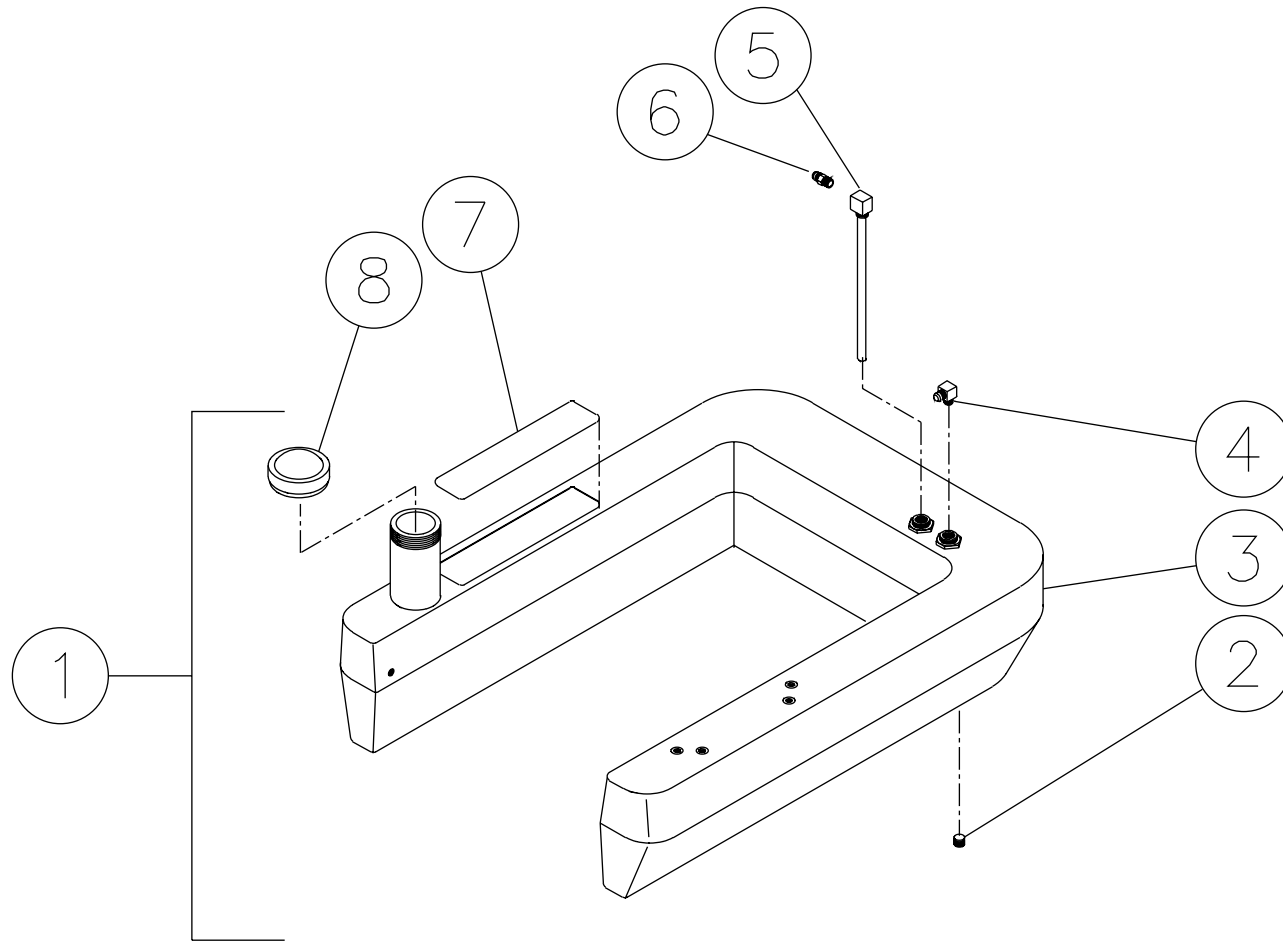

850-0214-121797-BAR

850-0214-121797-BAR

FUEL TANK (850-0214)			
REF. #	DESCRIPTION	PART #	QTY.
1	Fuel Tank Assembly (Inc. 2-8)	850-0214	1
2	Plug	23-0296	1
3	Fuel Tank (See 850-0214)	N/A Sep.	1
4	Elbow	23-0237	1
5	Fuel Pick-up Line	33-0270	1
6	Flare	23-0247	1
7	Decal-Warning-Risk of Fire (E/S)	34-0806	1
8	Fuel Cap-Vented	12-0033	1

FUEL PUMP (3-0020)

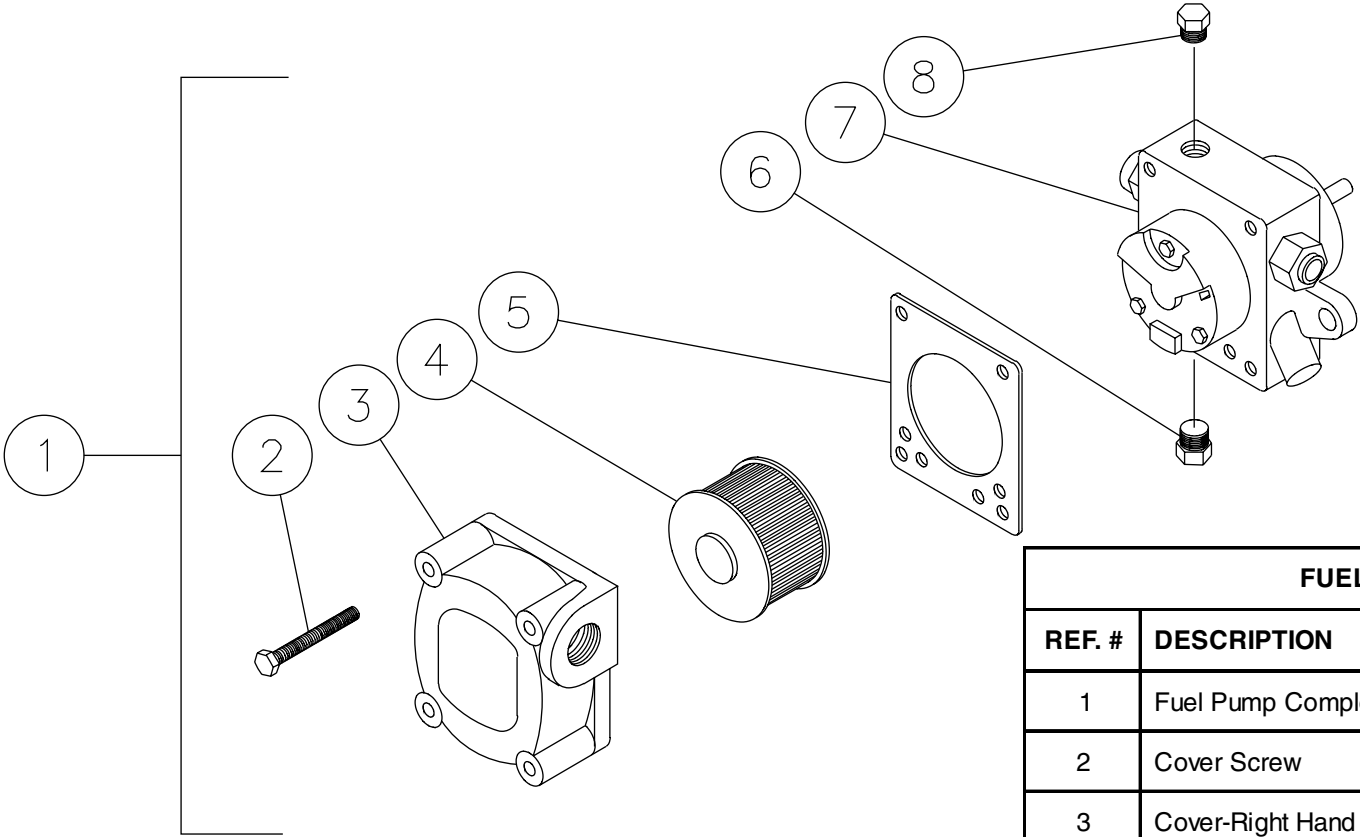

0MHSP018A-041597-BAR

FUEL PUMP (3-0020)			
REF. #	DESCRIPTION	PART #	QTY.
1	Fuel Pump Complete - Right Hand	3-0020	1
2	Cover Screw	46-1006	4
3	Cover-Right Hand	46-1005	1
4	Strainer	19-0034	1
5	Cover Gasket	26-0109	1
6	Plug	24-0044	3
7	Body	N/A	1
8	Plug	24-0082	1

0MHSP018-041597-BAR

FUEL SOLENOID (44-0101)

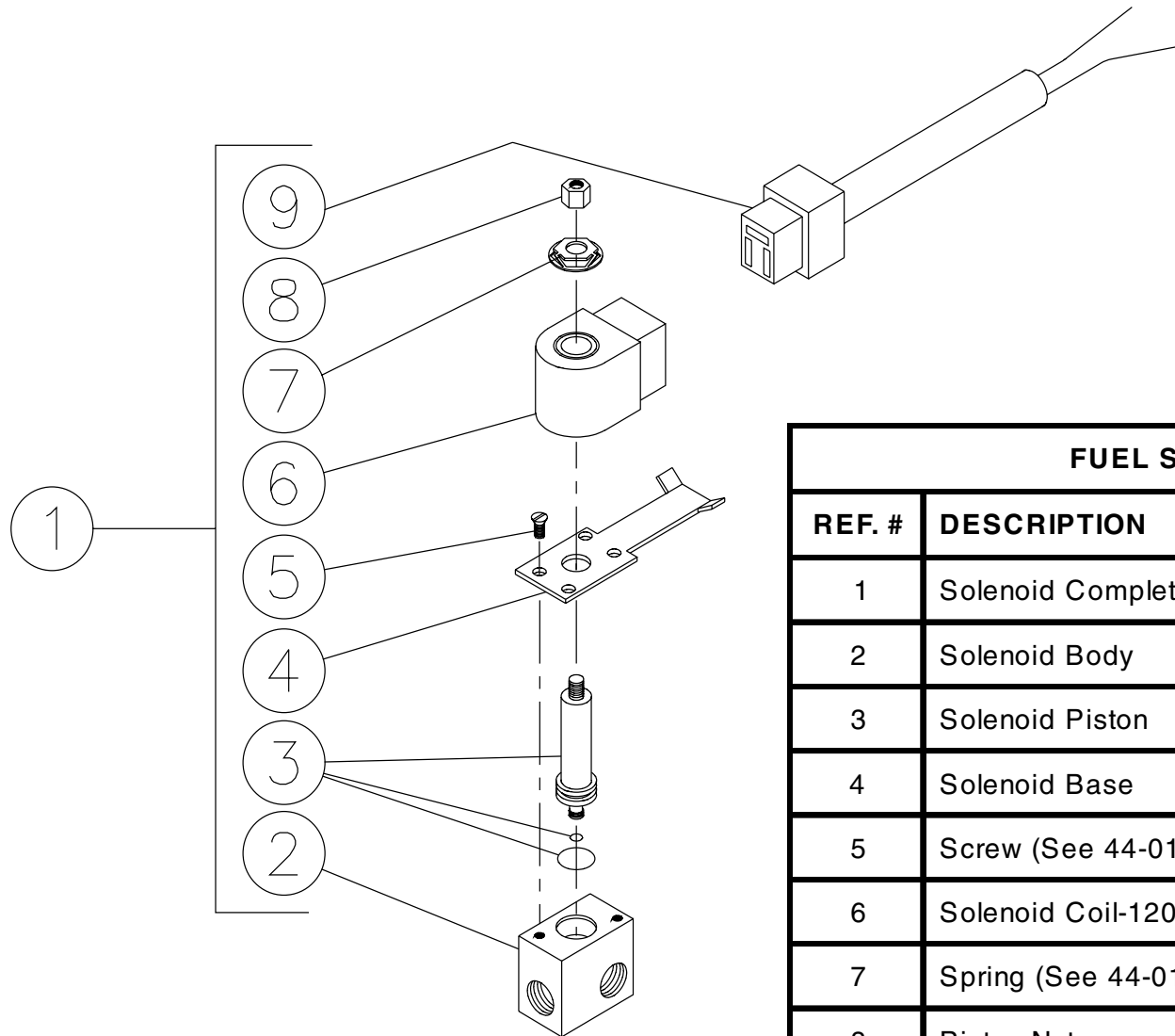

0MHSP013-44-0101-121698-BAR

FUEL SOLENOID (44-0101)			
REF. #	DESCRIPTION	PART #	QTY.
1	Solenoid Complete-120V	44-0101	1
2	Solenoid Body	46-1013	1
3	Solenoid Piston	46-1012	1
4	Solenoid Base	46-1014	1
5	Screw (See 44-0101)	N/A Sep.	2
6	Solenoid Coil-120V	46-1020	1
7	Spring (See 44-0101)	N/A Sep.	1
8	Piston Nut	46-1016	1
9	Din Connector Cord	32-0443	1

0MHSP013-041597-BAR

CONTROL PANEL

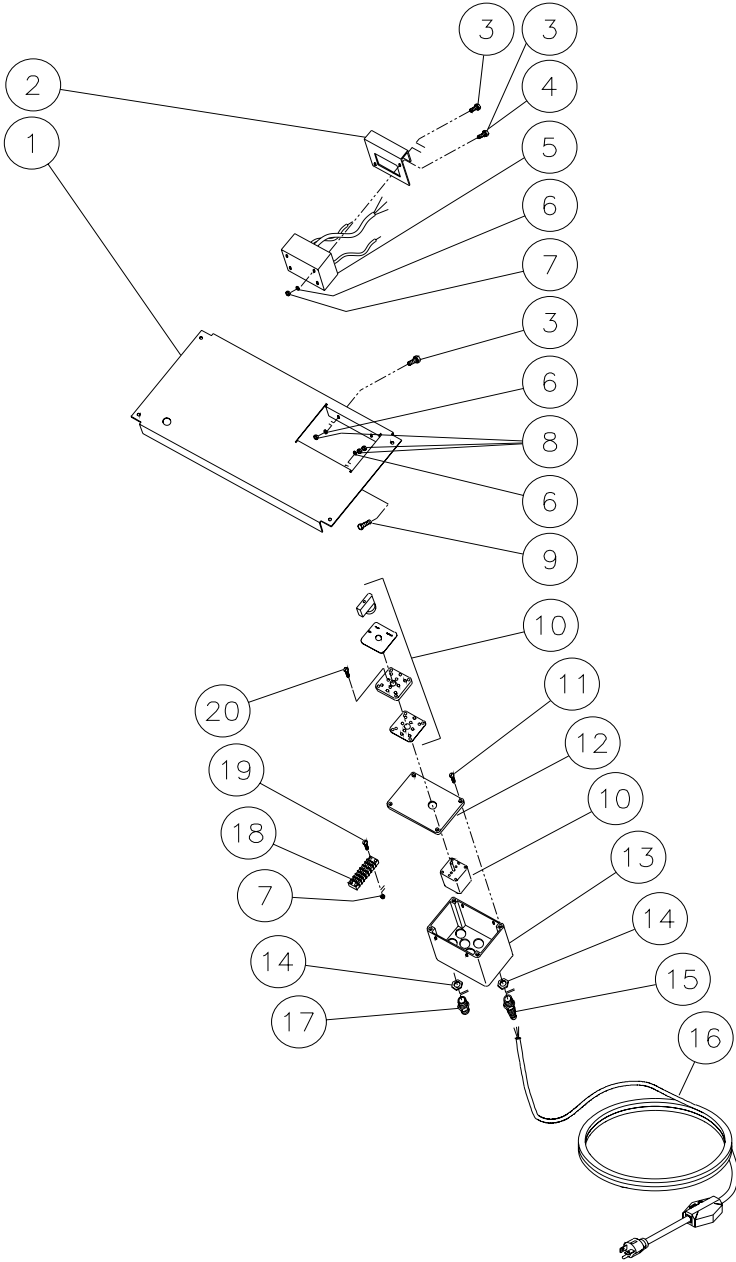

CONTROL PANEL			
REF. #	DESCRIPTION	PART #	QTY.
1	Control Panel	20-0405A01	1
2	Ignitor Bracket- 120 Volt	20-0414A01	1
3	Bolt	27-9526	7
4	Bolt	27-8899	-
5	Ignitor- 120 Volt	44-0104	1
6	Star Washer	28-1009	4
7	Hex Nut	30-0137	2
8	Hex Nut	30-6001	5
9	Bolt	27-8807	1
10	Cam Switch-1 Pole / 3 Position / 20 Amp	32-0434	1
11	Hardware Kit	70-0197	1
12	Lid-Black	32-0433A01	1
13	Electric Box-Black	32-0432A01	1
14	Locknut	32-0108	7
15	Strain Relief	32-0407	1
16	Electric Cord w/GFCI-120V/15 Amp	32-0268	1
17	Strain Relief	32-0437	6
18	Terminal Strip	32-0436	1
19	Bolt	27-8861	2
20	Screw	27-8897	2

WIRE SCHEMATIC

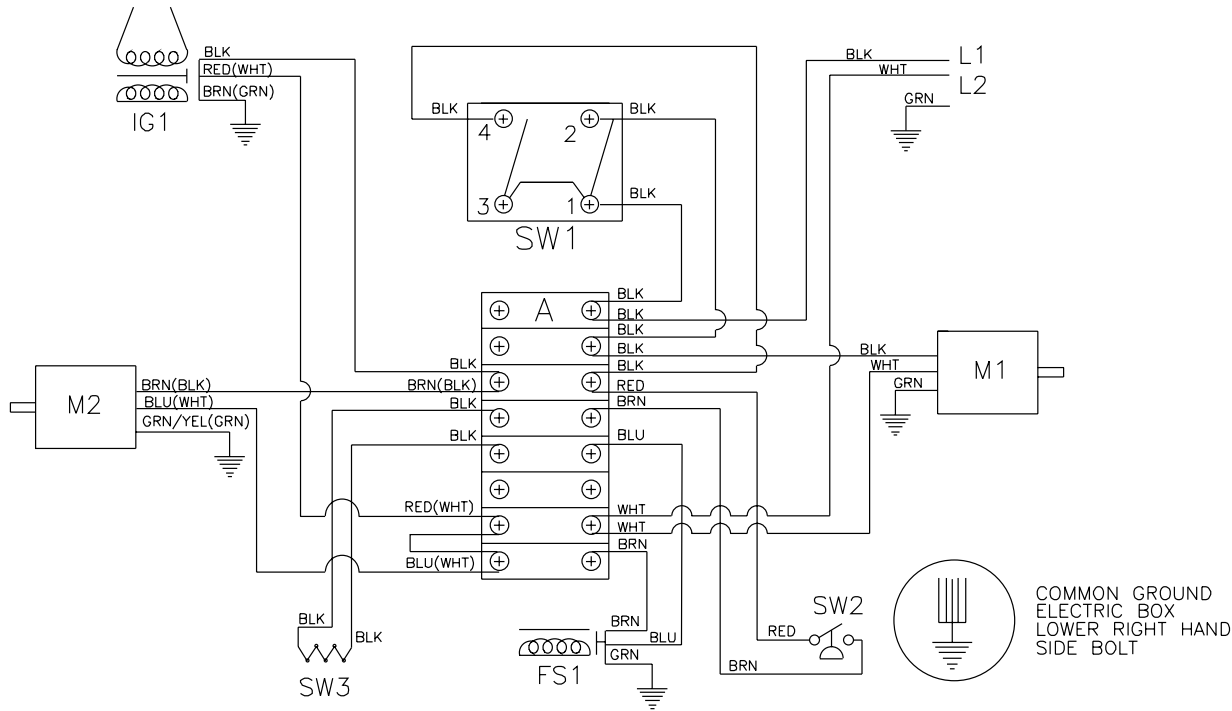

WIRE SCHEMATIC

OMHSE09S-052297-BAR

WIRING SCHEMATIC	
REF. #	DESCRIPTION
L1	Power (Black)
L2	Power (White)
M1	Pump Motor- 120 Volt
M2	Blower Motor-120 Volt
SW1	Cam Switch-1 Pole, 3 Position
SW2	Pressure Switch
SW3	Temp Switch
FS1	Fuel Solenoid-120 Volt
IG1	Igniter-120 Volt
A	Terminal Strip

OMHSE009-052297-BAR

WIRE DIAGRAM

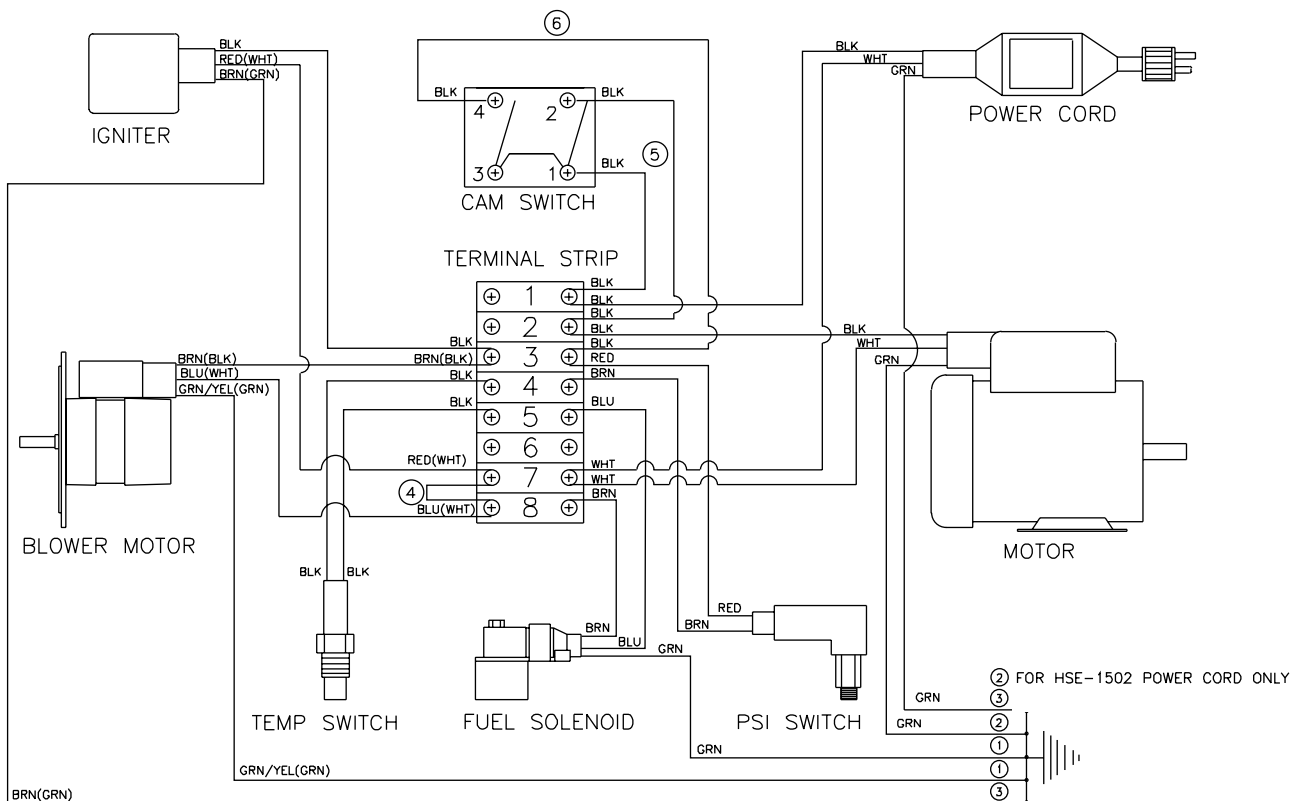

WIRE DIAGRAM

OMHSE09W-052297-BAR

WIRING DIAGRAM				
REF. #	DESCRIPTION	PART #	1002 QTY.	1502 QTY.
1	Ring Terminal-Red	32-0446	2	2
2	Ring Terminal-Yellow	32-0002	1	2
3	Ring Terminal-Blue	32-0044	2	1
4	Jumper Clip	32-0453	1	1
5	#12 Black Wire *(Two Feet Required)	32-0091	1	1
6	#16 Black Wire *(One Foot Required)	32-0256	1	1

*Must Order in One Foot Lengths

OMHSE009A/042697/BAR

NOTES

NOTES

